

User's Guide

TRENDNET[®]



**5 dBi Wireless AC1300 Outdoor
PoE+ Omni-Directional Access Point**

TEW-841APBO

Contents

Product Overview	1
Package Contents	1
Features	1
Product Hardware Features.....	3
Primary Product Application	5
Application Diagram	5
Minimum Installation Requirements	6
Wireless Installation Tips.....	6
Quick Reference	7
TEW-841APBO	7
TEW-841APBO Basic Installation and Configuration (Basic Access Point Setup)	8
Hardware Setup	8
Basic Access Point Configuration	8
TEW-841APBO Basic Installation and WDS Configuration (5GHz WDS Bridge & 2.4GHz AP).....	12
Note the WiFi MAC Addresses.....	12
Hardware Setup	13
TEW-841APBO #1 Configuration	13
TEW-841APBO #2 Configuration	18
Confirm Connectivity	19
Completed Installation Reference	20
Hardware and Mounting Installation	21
Waterproof Kit Installation	21
Pole Mount Installation	22

Application Modes.....	23
Access Point (AP)	23
Client Bridge	23
WDS Access Point (WiFi Distribution System)	24
WDS Station.....	24
WDS Bridge.....	25
Accessing your access point management page	26
Access your access point management page	26
Overview	27
Device Status	27
Connections.....	29
Real-time	29
Network	30
Basic.....	30
Wireless	31
Management	37
Advanced	37
Time Zone	38
WiFi Scheduler.....	39
Tools	40
System Manager	42
Account.....	42
Firmware	42
System Log.....	44
System Log.....	44
Technical Specifications	45

Appendix47

Product Overview

TEW-841APBO Overview



Package Contents

TEW-841APBO package includes:

- TEW-841APBO
- 2 x Detachable 2.4GHz 5 dBi antennas
- 2 x Detachable 5GHz 5 dBi antennas
- IP67 weather rated cable gland
- Mounting hardware
- Quick Installation Guide

If any package contents are missing or damaged, please contact the retail store, online retailer, or reseller/distributor from which the product was purchased.

Features

TRENDnet's 5 dBi Wireless AC1300 Outdoor PoE+ Omni-Directional Access Point, model TEW-841APBO, is designed for point-to-point and point-to-multi-point WiFi bridging applications. The wireless multi-point bridge can be powered with a PoE+ switch or PoE+ injector of your choosing. A variety of installation scenarios are facilitated with Access Point, WDS Bridge, WDS Access Point, WDS Station, and Client Bridge modes. The IP67 rated housing on the wireless multi-point bridge is designed for outdoor environments, and includes wall and pole mounting hardware.

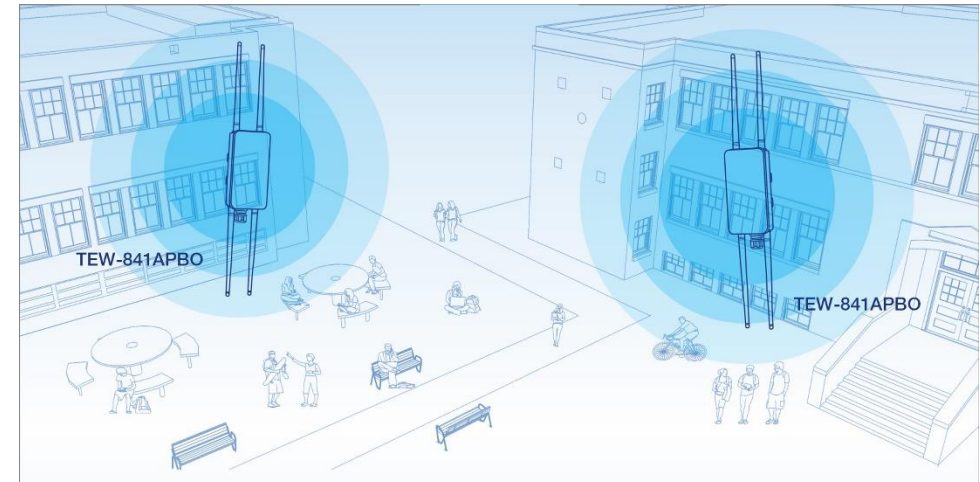

Wireless Multi-Point Bridge

Use this dual band wireless AC1300 point-to-multi-point bridge to conveniently link two or more locations together with wireless AC speeds and performance.*

Wireless Modes

Supports Access Point, WDS Bridge, WDS Access Point, WDS Station, and Client Bridge modes for a variety of wireless applications.

Outdoor Ready

Built for outdoor installations with an IP67 outdoor protection rating and an operating temperature range of -20° – 60° C (-4° – 140° F).

Concurrent Dual Band

AC1300: concurrent 867Mbps WiFi AC + 400Mbps WiFi N bands**

Omni-Directional Antenna

4 x 5 dBi detachable Omni-directional antennas

PoE Powered

Supports 802.3at PoE+ power input

Logs

Real time logs and statistics help troubleshooting

Encrypted Wireless

Support for wireless encryption of up to WPA2

Multiple SSID

Create up to eight dual band SSIDs with band steering capabilities

Mounting Hardware

Pole and wall mount hardware included

Compatibility

Compatible with legacy wireless devices

*Effective wireless coverage may vary depending on the wireless device's output power, antenna gain, antenna alignment, receiving sensitivity, and radio interference. Additionally environmental factors such as weather conditions, physical obstacles, and other considerations may affect performance. For optimal results, we recommended consulting a professional installer for site survey, safety precautions, and proper installation.

**Maximum wireless signal rates are referenced from IEEE 802.11 theoretical specifications. Actual data throughput and coverage will vary depending on interference, network traffic, building materials and other conditions. For maximum performance of up to 867Mbps use with an 867Mbps 802.11ac wireless adapter. For maximum performance of up to 400Mbps, use with a 400Mbps 802.11n wireless adapter. Multi-User MIMO (MU-MIMO) requires the use of multiple MU-MIMO enabled wireless adapters.

Product Hardware Features

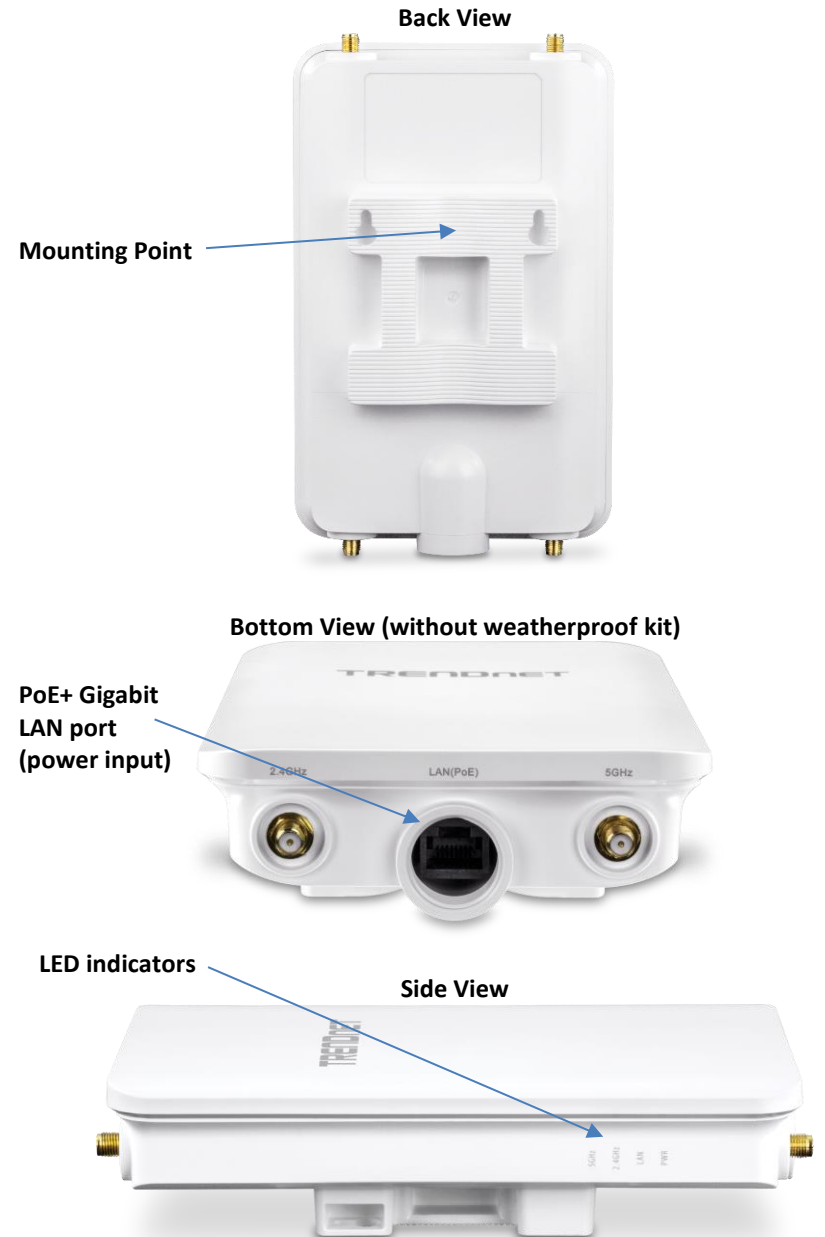
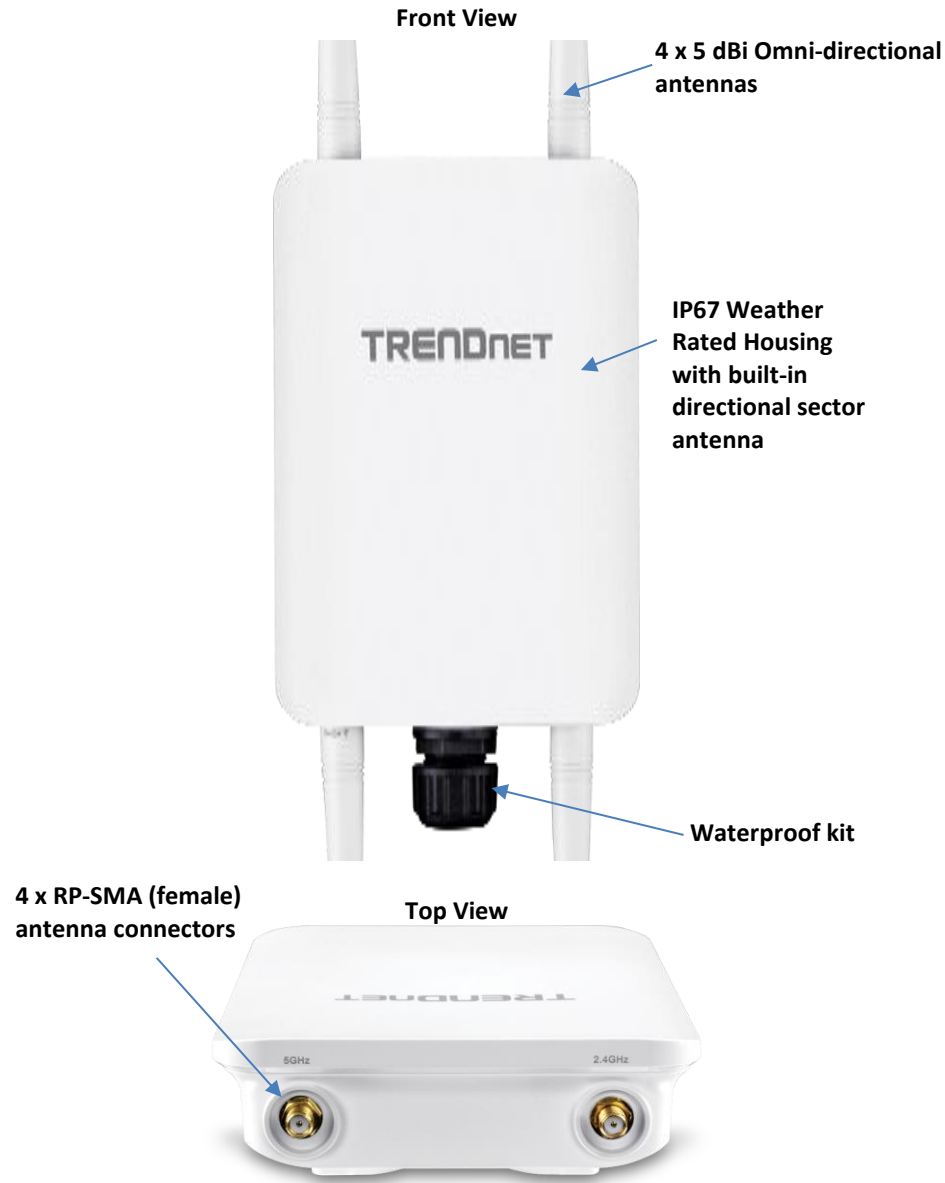

- **4 x RP-SMA (female) antenna connectors** – The access point ships with 4 x 5dBi Omni directional antennas. Please take note to connect the correct antenna, the antennas are tuned for optimizations on their labeled wireless bands.
- **Waterproof kit** – The access point comes with a waterproof cable guard for outdoor installations.
- **Mounting Point** – The access point can be wall or pole mounted using the mounting points on the unit, and the mounting kit included with the packaging.
- **PoE+ Gigabit LAN port (power input)** – This gigabit Ethernet interface will be used to power the access point using standard 802.11at PoE+ power source and provide gigabit network connectivity to the access point.
- **Power (PWR) LED** – When the LED is ON, this will indicate that the device is receiving power and OFF if the device is not receiving power.
- **LAN LED** – When the LED is ON, this indicates an active network connection to the LAN port on the proprietary PoE injector. When the LED is BLINKING, this indicates data is being transmitted or received on the LAN port.
- **2.4GHz LED** – When the LED is ON, the wireless radio on the device is on. When the LED is OFF, the wireless radio on the device has been disabled.
- **5GHz LED** – When the LED is ON, the wireless radio on the device is on. When the LED is OFF, the wireless radio on the device has been disabled.

Important Note:

It is recommended to use RJ-45 cables without any additional caps, molded caps, or boots specifically on the connector side that will be connected to the access point LAN1 (PoE) port to avoid any cable fitment issues.

Primary Product Application

The intended purpose and application for this product is to extend network connectivity across long physical distances outside of an area or building that lacks local connectivity using point-to-point or point-to-multipoint wireless bridging using 802.11 standards.

This allows two access points configured in point-to-point bridge capability can connect/link the two physical locations or buildings together through an encrypted wireless connection.

Although this product supports multiple wireless modes, the basic installation will only cover the primary application of point to point wireless connectivity in WDS (Wireless Distribution System) Mode using AES encryption for security.

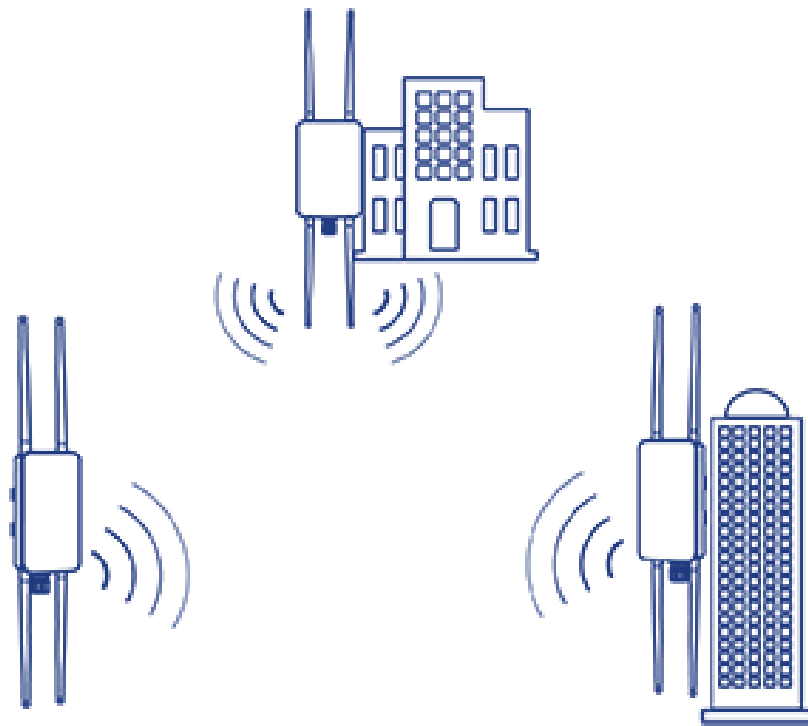

Application Diagram

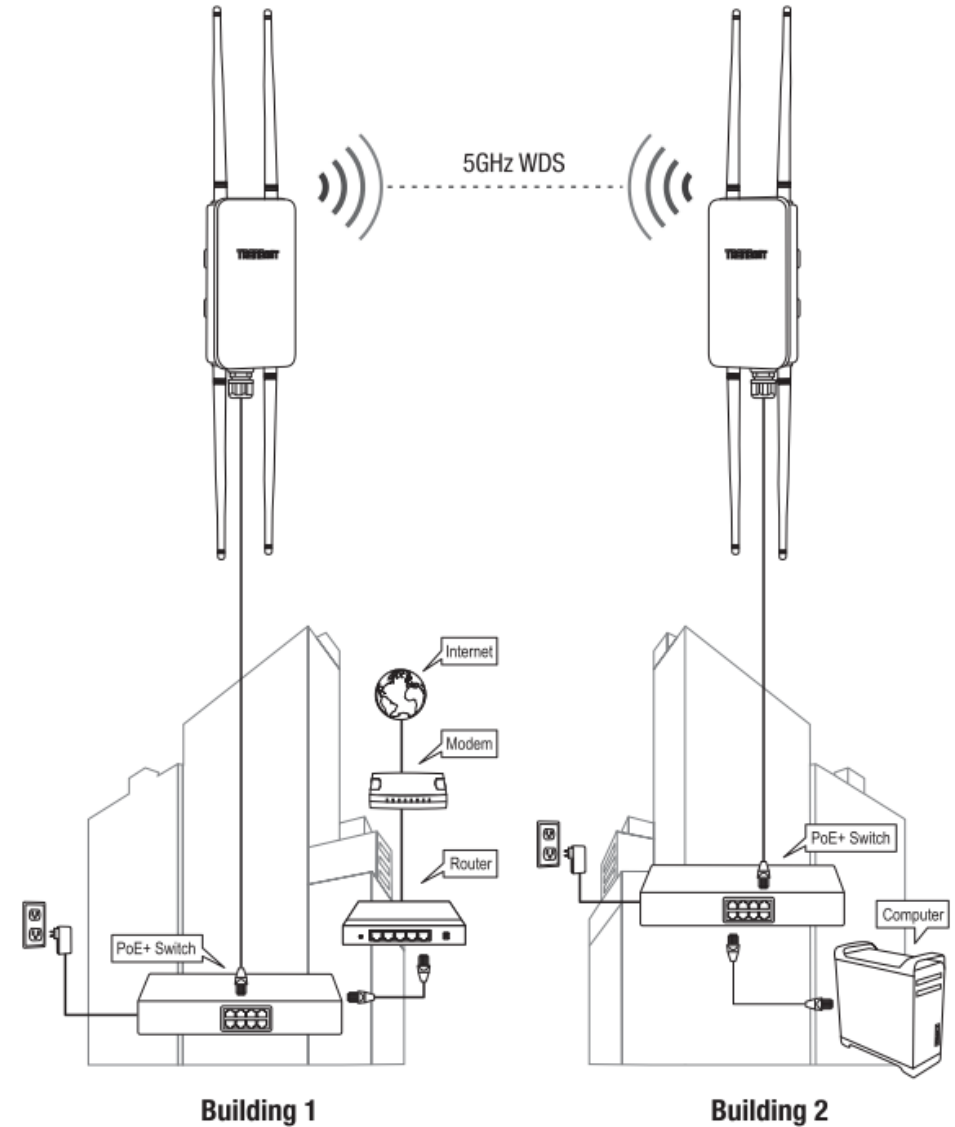

The example application displays two TEW-841PBO access points establishing a wireless link between each other, both configured in WDS Bridge; allowing for network connectivity between two buildings over a point-to-point wireless link.

Minimum Installation Requirements

- Computer with RJ-45 Ethernet port and web browser
- RJ-45 Ethernet cables (not included)
- Additional TRENDnet TEW-841APBO or TEW-841APBO (optional for point-to-point bridging)
- Flat head screwdriver for pole mounting clamp

For wall mounting only (included wall mounting kit for drywall installations only)

- Philips driver bit or screwdriver
- Power drill/driver (for mounting anchors)
- 7/16 in (2.75 mm) straight drill bit for hard wood or 3/32 in (2.35 mm) bit for soft wood (for mounting screws)
- 11/16 in (4.3 mm) straight drill bit for hard wood or 5/32 in (4 mm) bit for soft wood (if required for drywall anchors)

Note: The access point complies with IEEE 802.3at Power over Ethernet (PoE+) standard and can be used with other 802.3at PoE+ switches or injectors to deliver both power and data to the access point through the network LAN (PoE) port.

IMPORTANT NOTE: This device does not have a hardware reset button. When changing the administrator password to the access point configuration page, please make sure to write down your new password.

COMPATIBILITY NOTE: If you are establishing WDS bridge connections to TRENDnet TEW-740APBO H/W: v2.0R outdoor access points, please make sure to upgrade the TEW-740APBO H/W: v2.0R access points to firmware **2.10 or above** for WDS compatibility with TEW-841APBO.

Wireless Installation Tips

There are a number of factors that can impact the range of wireless devices.

1. Adjust your wireless devices so that the signal is traveling in a straight path, rather than at an angle. The more material the signal has to pass through the more signal you will lose.
2. Keep the number of obstructions to a minimum. Each obstruction can reduce the range of a wireless device. Position the wireless devices in a manner that will minimize the amount of obstructions between them.
3. Building materials can have a large impact on your wireless signal. In an indoor environment, try to position the wireless devices so that the signal passes through less dense material such as dry wall. Dense materials like metal, solid wood, glass or even furniture may block or degrade the signal.
4. Antenna orientation can also have a large impact on your wireless signal. Use the wireless adapter's site survey tool to determine the best antenna orientation for your wireless devices.
5. Interference from devices that produce RF (radio frequency) noise can also impact your signal. Position your wireless devices away from anything that generates RF noise, such as microwaves, radios and baby monitors.

If you are still experiencing low or no signal consider repositioning the wireless devices or installing additional access points. The use of higher gain antennas may also provide the necessary coverage depending on the environment. Please note to use the wireless connection quality indicators during installation to determine the optimal positioning when mounting your access points.

Quick Reference

TEW-841APBO

Note: By default, the wireless network name/SSID and wireless encryption settings have been pre-configured for your convenience and can be located on the included preset wireless sticker. The access point web management configuration page can be accessed using the URL <http://tew-841apbo> or using the LAN IP address of the device. The IP address settings by default is set to DHCP, but if no DHCP server is present on the network, then it will default to <http://192.168.10.100>.

Important Note:

Purchasing this model requires the access points to be properly configured to establish the wireless link/bridged connection to each other and verifying connectivity first before mounting the access points in their desired locations.

Default Settings

<http://tew-841apbo>
 LAN IP Address: 192.168.10.100 (DHCP)
 LAN Subnet Mask: 255.255.255.0
 Channel Access Method: CSMA/CA
 Mode: Access Point (AP) Mode
 WPA2 Encryption Key: <predefined>
 User: admin
 Password: admin

Preset Wireless Settings	
Wi-Fi Name/SSID (AC/N) TRENDnet841_5GHz_XXXX (N/B/G) TRENDnet841_2.4GHz_XXXX	
Wi-Fi Password XXXXXXXXXX	
Management Login http://tew-841apbo username: admin password: admin	

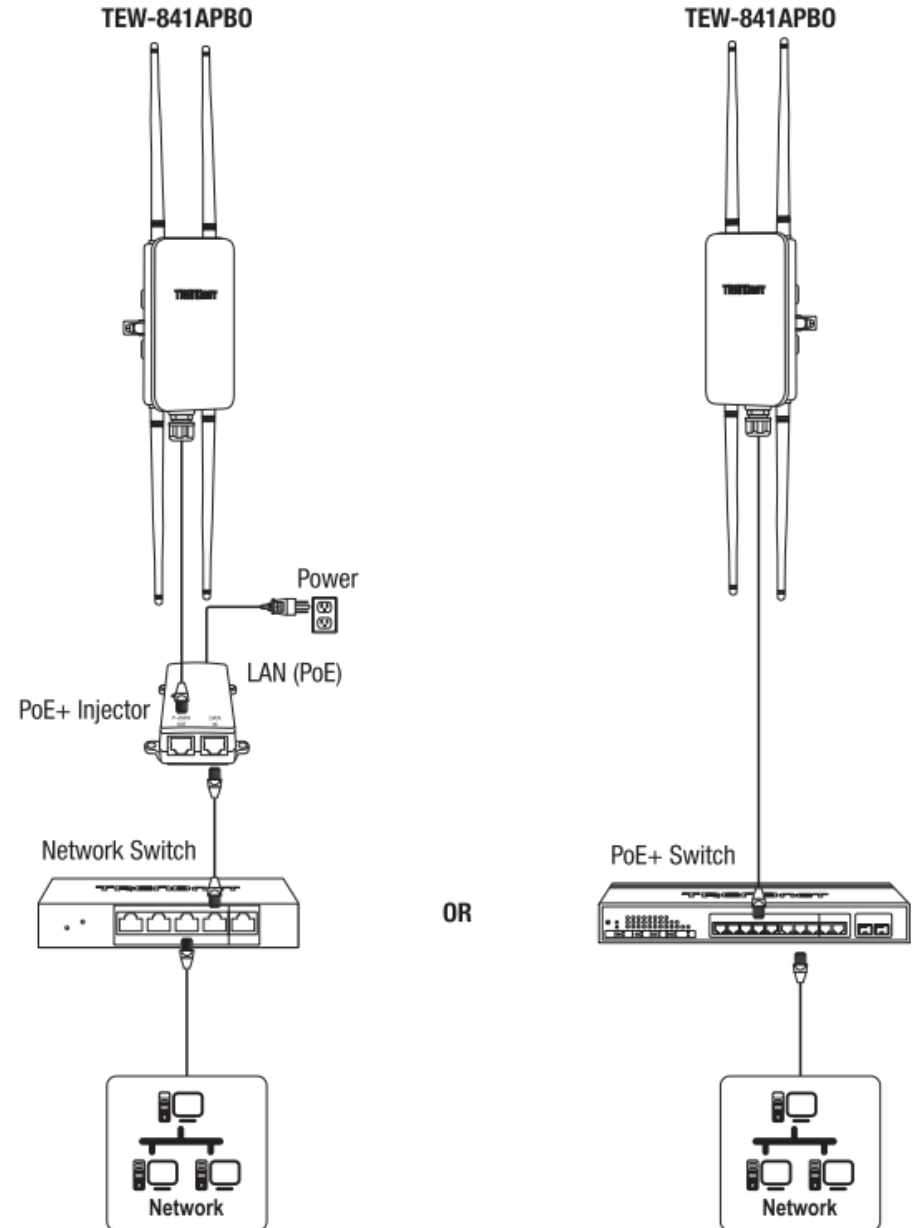

TEW-841APBO Basic Installation and Configuration (Basic Access Point Setup)

The following installation procedure is for setting up the TEW-841APBO as a basic outdoor Omni-directional access point.

Hardware Setup

1. Attach the antennas as shown in the following image.

NOTE: There are two different sets of antennas, one tuned for 2.4GHz, the other tuned for 5GHz. **Be sure to attach each antenna to its respective band for optimal performance.**

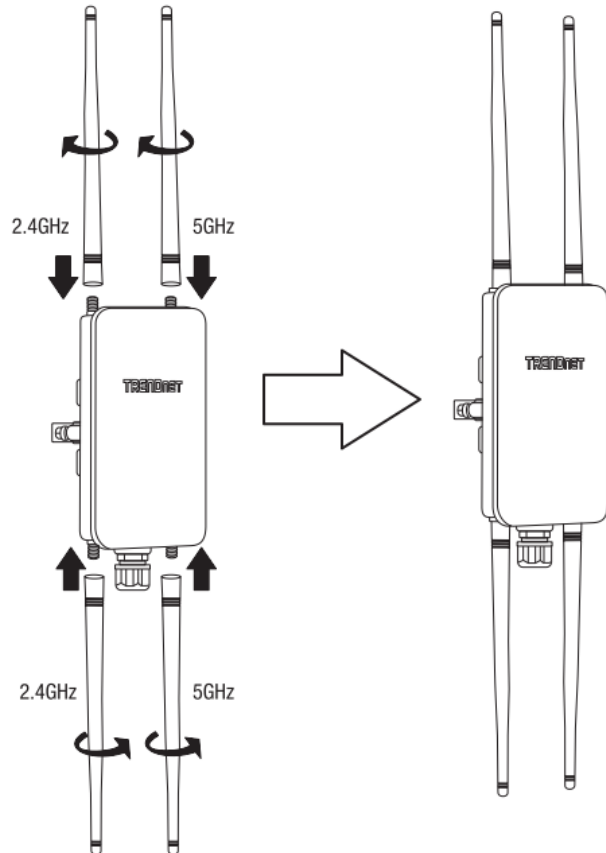

Basic Access Point Configuration

Note: It is strongly recommended to configure the access point first, prior to mounting.

1. Using a RJ-45 network cable, connect the cable from the LAN (PoE) port of your access point, to an available LAN PoE+ port on your networked switch or PoE+ injector.
2. Using another RJ-45, connect your computer's Ethernet port to the same PoE+ device chosen in step 1.

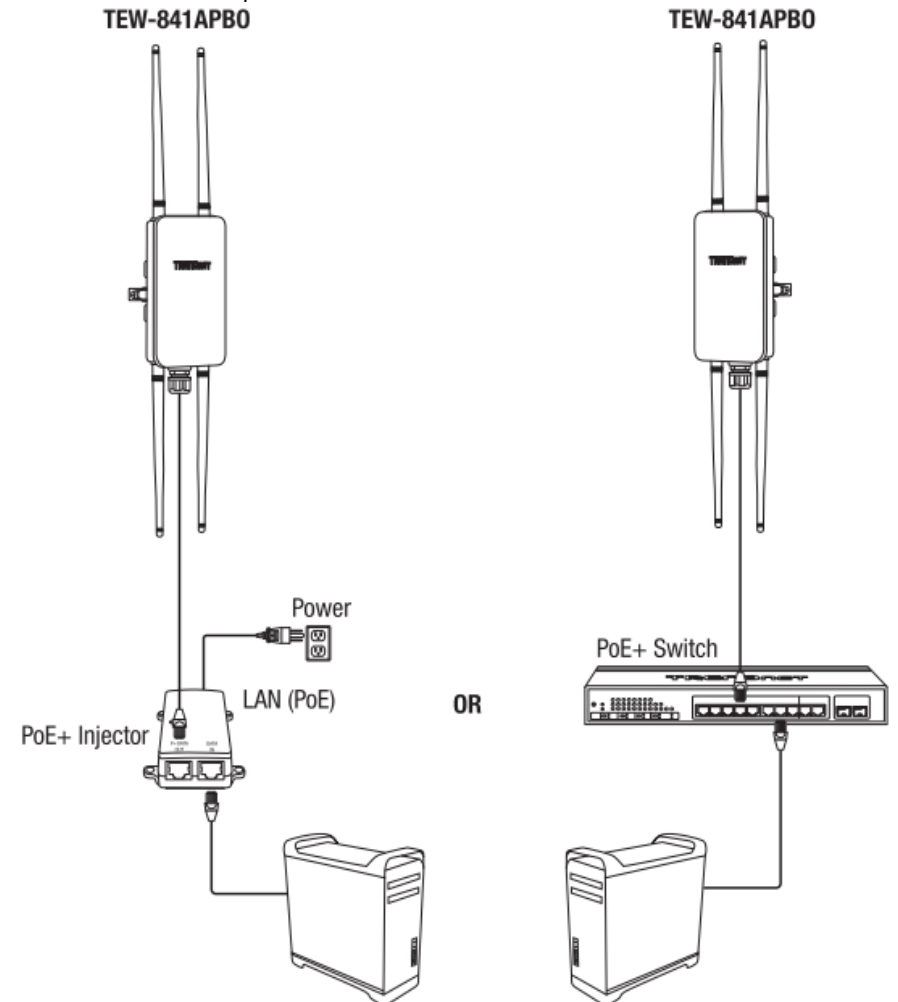

3. Confirm the device is powered on through the LED indicators.

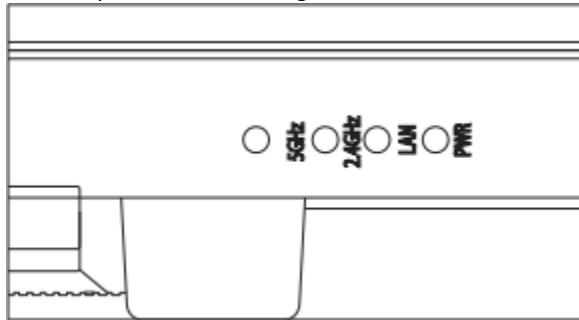

4. Assign a static IP address to your computer's network adapter in the subnet of 192.168.10.x (e.g. 192.168.10.10) and subnet mask of 255.255.255.0.

Note: For information on how to statically assign your IP address, see the Appendix section.

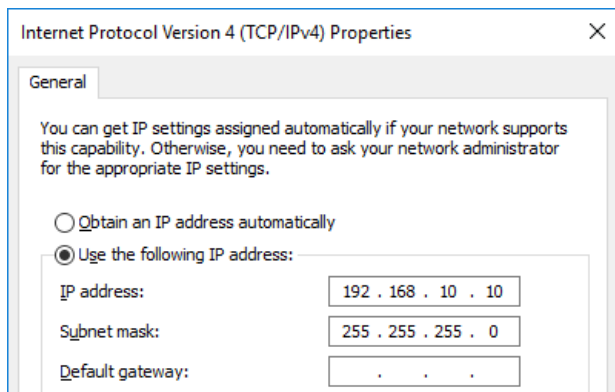

5. Open your web browser and type in the default IP address of the access point in the address bar, then press **Enter**. The default IP address of the access point is 192.168.10.100.

<http://tew-841apbo>

<http://192.168.10.100>

6. When prompted, login to the access point management page using the default user name and password settings.

- User Name: admin
- Password: admin

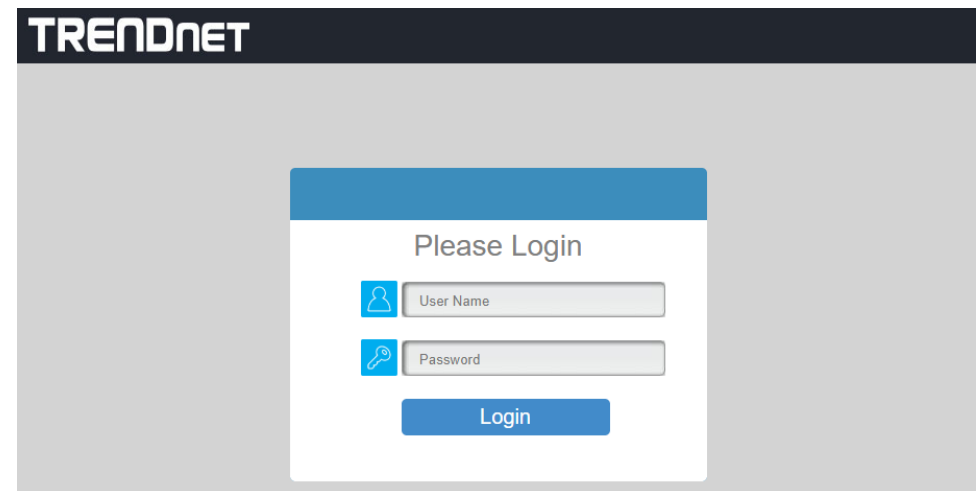

7. To change the administrator password, click on the **Account** tab under **System Manager** Category at the bottom of the left menu.

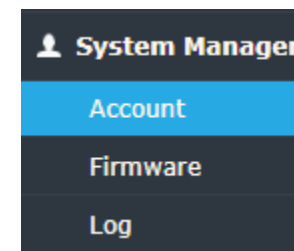

IMPORTANT NOTE: This device does not have a hardware reset button. When changing the administrator password to the access point configuration page, please make sure to write down your new password.

8. Change the default administrator password by first entering the default password (admin), then typing in the new password in the fields provided and then click the **Apply** button at the bottom of the page.
Note: Clicking the green "refresh" button will display hidden characters typed in the field.

TRENDnet
TEW-840APBO

Changes: 0 Reset Logout

Overview

Device Status

Connections

Real-time

Network

Basic

Wireless

Account Settings

Administrator Username

Current Password

New Password

Verify Password

Apply

IMPORTANT NOTE: This device does not have a hardware reset button. When changing the administrator password to the access point configuration page, please make sure to write down your new password.

9. Upon clicking apply, you will return to the login screen. Please enter the newly configured credentials to log back in.

10. Click on the **Basic** tab under **Network** category in the left hand menu.

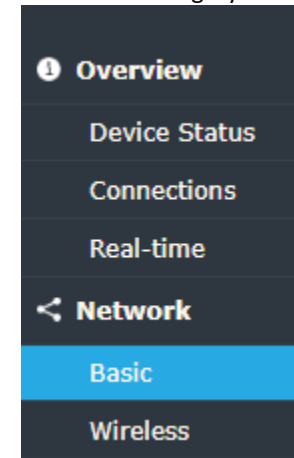

11. Under the IPv4 Settings section, select **Static IP** and enter your chosen IP Address, Subnet Mask, and Gateway, then click **Save** at the bottom of the page.

TRENDnet
TEW-840APBO

Changes: 0 Reset Logout

Overview

Device Status

Connections

Real-time

Network

Basic

Wireless

IPv4 Settings

IP Network Setting DHCP Static IP

IP Address

Subnet Mask

Gateway

Primary DNS

Secondary DNS

MAKE SURE THE CHANGES TO THE CONFIGURATIONS ARE APPLIED

12. The page should now have two indicators regarding pending changes:

1. Top right menu of the page:

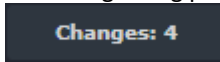

2. Bottom right of the page:

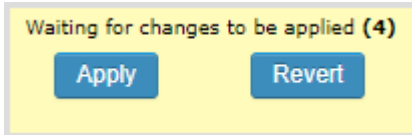

Note: Settings configured on the Access Point are not applied until you click apply changes. In order to minimize time spent waiting for the Access Point to reboot when applying settings, we recommend configuring all necessary settings and changes prior to apply & reboot of the device.

13. To configure your wireless network name/SSID and wireless encryption settings, click **Wireless** under **Network** in the left hand menu.

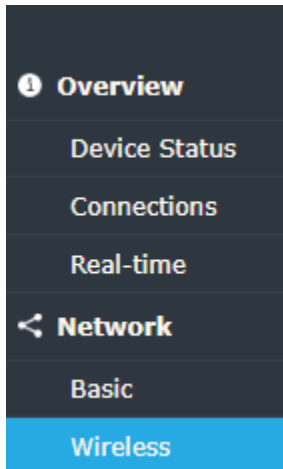

Note: By default, the wireless network name/SSID and wireless encryption has been preconfigured for your convenience and can be located on the included wireless sticker. If you are modifying the wireless settings, you will need to connect/reconnect all clients to the access point using the new credentials.

14. To change the wireless network name/SSID, under the wireless settings – Access Point section, select which band you would like to configure, and enter the name in the **SSID** field. Click **Save** at the bottom of the page to temporarily save the settings.

Wireless Settings - Access Point

Enabled	SSID	2.4GHz	5GHz	Edit	Security	Guest Network	VLAN ID
<input checked="" type="checkbox"/>	TRENDnet841_2.4GHz_04	<input checked="" type="checkbox"/>	<input type="checkbox"/>	Edit	WPA2/PSK AES	<input type="checkbox"/>	-
<input checked="" type="checkbox"/>	TRENDnet841_5GHz_041	<input type="checkbox"/>	<input checked="" type="checkbox"/>	Edit	WPA2/PSK AES	<input type="checkbox"/>	-

15. To change the wireless encryption key for the selected wireless band click **Edit**. A pop-up window will appear. ****You may need to disable your browser's pop-up blocker.**

Wireless Settings - Access Point

Enabled	SSID	2.4GHz	5GHz	Edit	Security	Guest Network	VLAN ID
<input checked="" type="checkbox"/>	TRENDnet841_2.4GHz_04	<input checked="" type="checkbox"/>	<input type="checkbox"/>	Edit	WPA2/PSK AES	<input type="checkbox"/>	-
<input checked="" type="checkbox"/>	TRENDnet841_5GHz_041	<input type="checkbox"/>	<input checked="" type="checkbox"/>	Edit	WPA2/PSK AES	<input type="checkbox"/>	-

16. Under the Wireless Security section, enter the encryption key in the **Passphrase** field. Click **Save** at the bottom of the page to temporarily save the settings.

MAKE SURE THE CHANGES TO THE CONFIGURATIONS ARE APPLIED

17. The page should now have two indicators regarding pending changes:

1. Top right menu of the page:

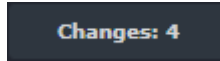

2. Bottom right of the page:

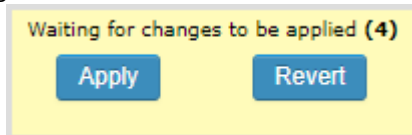

Note: Settings configured on the Access Point are not applied until you click apply changes. In order to minimize time spent waiting for the Access Point to reboot when applying settings, we recommend configuring all necessary settings and changes prior to apply & reboot of the device.

TEW-841APBO Basic Installation and WDS Configuration (5GHz WDS Bridge & 2.4GHz AP)

The following installation procedure is for configuring **two TEW-841APBO's** as Omni-directional access points, wirelessly bridged to each other using WDS link. This example configuration uses the **5GHz** radio as a **dedicated WDS Bridge** backhaul, with the **2.4GHz** radio configured as a **standard access point** for client connections.

Note:

1. The initial configuration should be done in a testing environment with the two TEW-841APBO access points approximately 15 ft. (5 m) apart from one another.
2. It is strongly recommended to configure and connect the access points prior to mounting them in their intended locations.
3. In this example, we will configure the two access points to establish a WDS bridge using the 5GHz radio, while leaving the 2.4GHz radio standard 802.11 for client connections.

Note: This example installation procedure will be demonstrated using the following example network information:

Router/Default Gateway IP Address: 192.168.10.1
 Subnet Mask: 255.255.255.0

Using the above information, we will configure the TEW-841APBO access points will be configured with the following settings:

	TEW-841APBO #1	TEW-841APBO #2
IP Address	192.168.10.50	192.168.10.51
Netmask (Subnet Mask)	255.255.255.0	255.255.255.0
IP Gateway (Default Gateway)	192.168.10.1	192.168.10.1
Primary DNS	192.168.10.1	192.168.10.1

Note the WiFi MAC Addresses

1. Write down the 5GHz MAC address (WiFi 5GHz) of both the TEW-841APBO #1 and TEW-841APBO #2 access points. The MAC address can be found on the label on the back of the access point.



Note: In this installation procedure example, we will assume the following for the 5GHz WiFi MAC addresses:

	TEW-841APBO #1	TEW-841APBO #2
5GHz WiFi MAC Address	00:11:22:33:44:00	00:11:22:33:44:11

Hardware Setup

1. Attach the antennas as shown in the following image.

NOTE: There are two different sets of antennas, one tuned for 2.4GHz, the other tuned for 5GHz. Be sure to attach each antenna to its respective band for optimal performance.

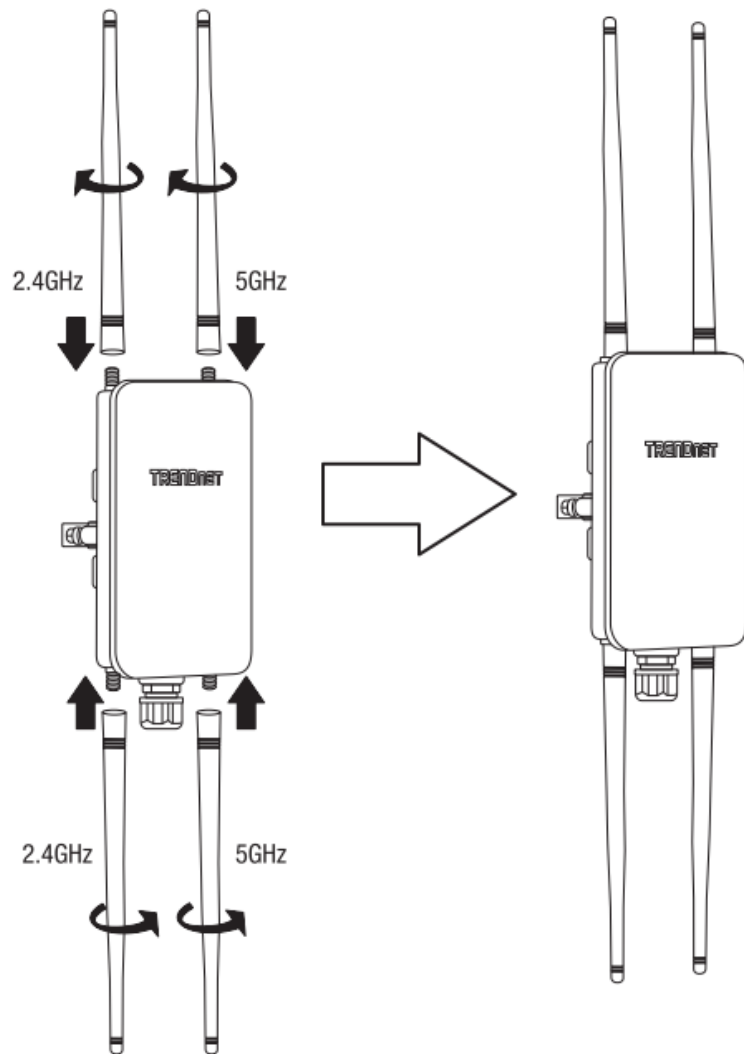

TEW-841APBO #1 Configuration

Note: It is strongly recommended to configure the access point first, prior to mounting.

1. Using a RJ-45 network cable, connect the cable from the LAN (PoE) port of your access point, to an available LAN PoE+ port on your networked switch or PoE+ injector.
2. Using another RJ-45, connect your computer's Ethernet port to the same PoE+ device chosen in step 1.

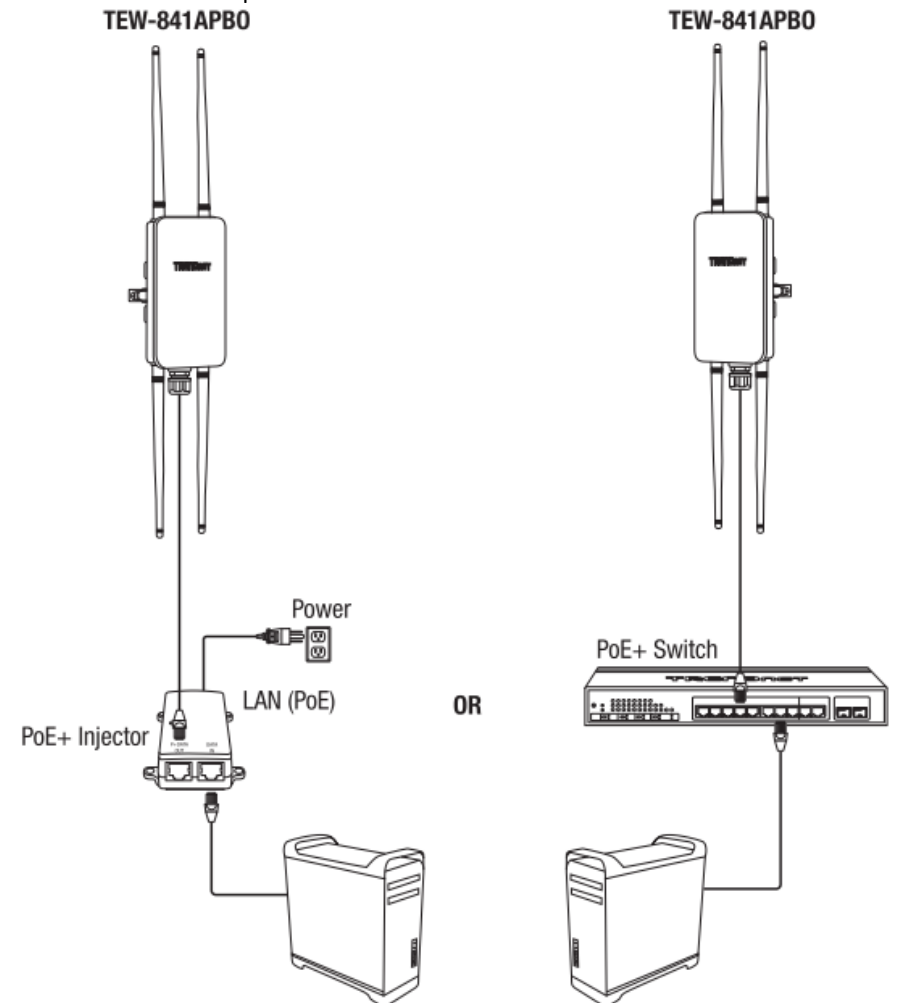

3. Confirm the device is powered on through the LED indicators.

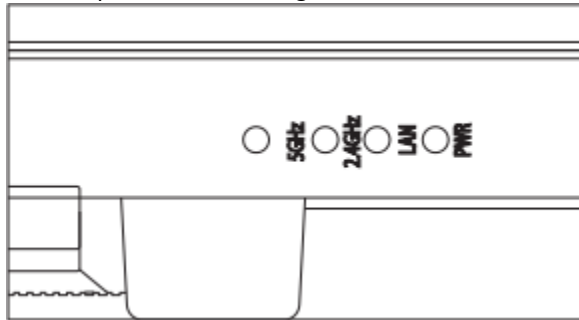

4. Assign a static IP address to your computer's network adapter in the subnet of 192.168.10.x (e.g. 192.168.10.10) and subnet mask of 255.255.255.0.

Note: For information on how to statically assign your IP address, see the Appendix section.

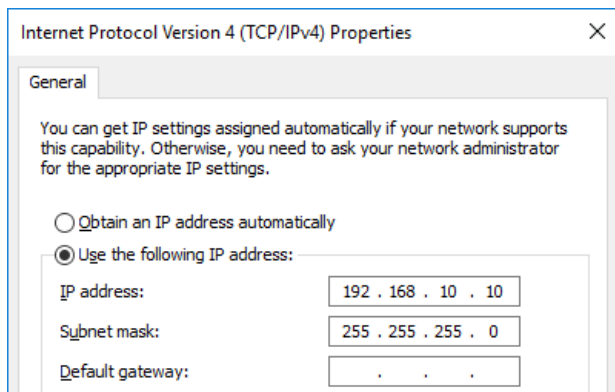

5. Open your web browser and type in the default IP address of the access point in the address bar, then press **Enter**. The default IP address of the access point is 192.168.10.100.

<http://tew-841apbo>

<http://192.168.10.100>

6. When prompted, login to the access point management page using the default user name and password settings.

- User Name: admin
- Password: admin

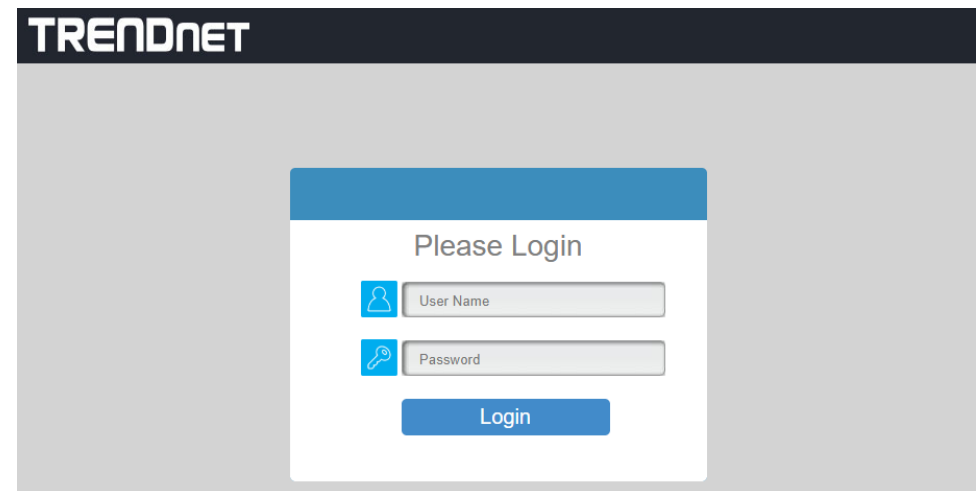

7. To change the administrator password, click on the **Account** tab under **System Manager** Category at the bottom of the left menu.

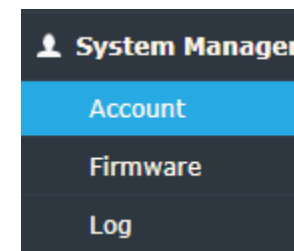

IMPORTANT NOTE: This device does not have a hardware reset button. When changing the administrator password to the access point configuration page, please make sure to write down your new password.

8. Change the default administrator password by first entering the default password (admin), then typing in the new password in the fields provided and then click the **Apply** button at the bottom of the page.
Note: Clicking the green "refresh" button will display hidden characters typed in the field.

IMPORTANT NOTE: This device does not have a hardware reset button. When changing the administrator password to the access point configuration page, please make sure to write down your new password.

9. Upon clicking apply, you will return to the login screen. Please enter the newly configured credentials to log back in.

10. Click on the **Basic** tab under **Network** category in the left hand menu.

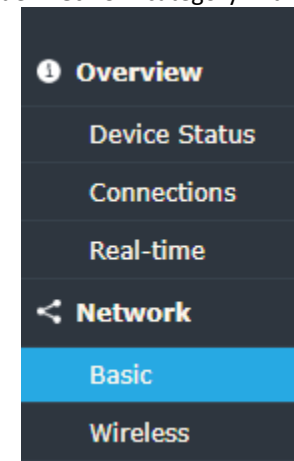

11. Under the IPv4 Settings section, select **Static IP** and enter the IP Address **192.168.10.50**, Subnet Mask **255.255.255.0**, Gateway **192.168.10.1**, and Primary DNS **192.168.10.1** then click **Save** at the bottom of the page to temporarily save your settings.

Note: Settings configured on the Access Point are not applied until you click apply changes. In order to minimize time spent waiting for the Access Point to reboot when applying settings, we recommend configuring all necessary settings and changes prior to apply & reboot of the device. You may choose to configure and save first, then apply everything together at the end.

MAKE SURE THE CHANGES TO THE CONFIGURATIONS ARE APPLIED

12. The page should now have two indicators regarding pending changes:

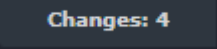
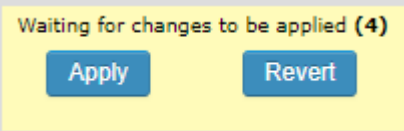
- Top right menu of the page: 
- Bottom right of the page: 

13. To configure your wireless settings, click **Wireless** under **Network** in the left hand menu.

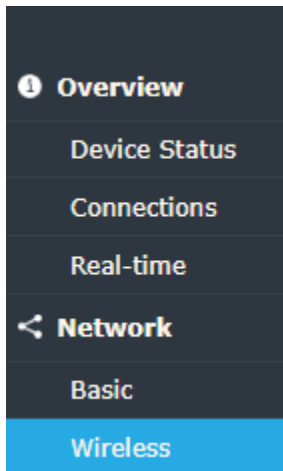

14. Under **5GHz**, click the **Operation Mode** drop-down list and select **WDS Bridge**.

- Keep the **2.4GHz** in the default **Access Point** mode.

	2.4GHz	5GHz
Operation Mode	Access Point ▼	WDS Bridge ▼
Wireless Mode	802.11 B/G/N ▼	802.11 AC/N ▼

15. Click **Configuration** next to **Channel**.

Note: The channel for TEW-841APBO #1 and TEW-841APBO #2 **must** be the same.

	2.4GHz	5GHz
Operation Mode	Access Point ▼	WDS Bridge ▼
Wireless Mode	802.11 B/G/N ▼	802.11 AC/N ▼
Channel HT Mode	20MHz ▼	80MHz(AC Only) ▼
Channel		Configuration

- Within the new popup window, please select **Ch. 48** then click **Save**. (Note, the greyed out channel is the currently selected channel).

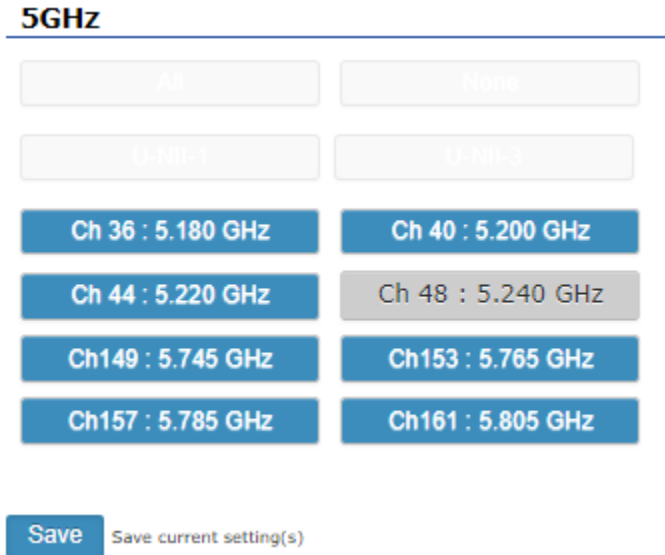

Note: Certain browsers and popup blockers may block the configuration popup windows. Check to make sure there is nothing blocking the window from appearing if you do not see it.

16. To change the wireless network name/SSID, scroll down on the previous page (**Wireless** tab under the **Networking** category) and identify the **Wireless Settings – Access Point** section, and enter the name for the 2.4GHz WiFi in the **SSID** field. To change the wireless encryption key, click **Edit**. A pop-up window will appear.

Wireless Settings - Access Point

Enabled	SSID	2.4GHz	5GHz	Edit	Security	Guest Network	VLAN ID
<input checked="" type="checkbox"/>	TRENDnet841_2.4GHz_04	<input checked="" type="checkbox"/>	<input type="checkbox"/>	Edit	WPA2/PSK AES	<input type="checkbox"/>	-
<input type="checkbox"/>	TRENDnet841_5GHz_041	<input type="checkbox"/>	<input checked="" type="checkbox"/>		WPA2/PSK	<input type="checkbox"/>	-

- Under the Wireless Security section, enter the encryption key in the Passphrase field. Click **Save** at the bottom of the page to temporarily save the settings.

Wireless Security

Security Mode	WPA2-PSK
Encryption	AES
Passphrase	841A1000001
Group Key Update Interval	3600 (30~3600; 0:Disable)

Note: By default, the wireless network name/SSID and wireless encryption has been preconfigured for your convenience and can be located on the included wireless sticker. If you are modifying the wireless settings, you will need to connect/reconnect all clients to the access point using the new credentials.

17. Scroll down on the previous page (**Wireless** tab under the **Networking** category) and identify the **WDS Link Settings – 5GHz** section, click on the **Security** drop-down list and select **AES**. Enter your chosen WDS encryption key in the **AES Passphrase** field (8-63 alphanumeric characters).

Note: When configuring TEW-841APBO #2, the WDS AES Passphrase **must** be the same as TEW-841APBO #1.

WDS Link Settings - 5GHz

Security	AES
AES Passphrase	XXXXXXXXXX (8-63 ASCII characters or 64 hexadecimal digits)

18. Just below, under the **MAC Address** section, click the **Mode** drop-down list and select **Enable**. In the fields provided, enter the 5GHz MAC address off **TEW-841APBO #2** and click **Save** at the bottom of the page to temporarily save your settings.

Caution: NAWDS is enabled, please assign the Channel on both frequency bands manually for settings to take effect.

MAC Address	Mode
00 : 11 : 22 : 33 : 44 : 11	Enable
	Disable

MAKE SURE THE CHANGES TO THE CONFIGURATIONS ARE APPLIED

19. The page should now have two indicators regarding pending changes:

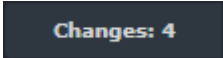
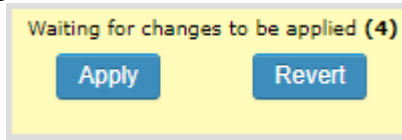
- Top right menu of the page: 
- Bottom right of the page: 

Note: Settings configured on the Access Point are not applied until you click apply changes. In order to minimize time spent waiting for the Access Point to reboot when applying settings, we recommend configuring all necessary settings and changes prior to apply & reboot of the device.

TEW-841APBO #2 Configuration

When configuring TEW-841APBO #2, repeat all steps in [TEW-841APBO #1](#) aside from the following:

- In **Step 11**, under **IPv4 Settings**, select **Static IP** and enter the IP address **192.168.10.51**, Subnet Mask **255.255.255.0**, Gateway **192.168.10.1**, and Primary DNS **192.168.10.1** then click **Save** at the bottom of the page to temporarily save your settings.

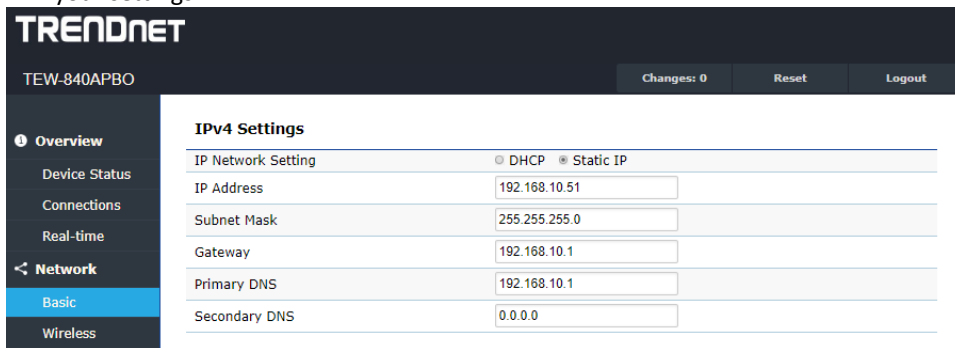

TRENDnet
TEW-840APBO

Changes: 0 Reset Logout

Overview

Device Status

Connections

Real-time

Network

Basic

Wireless

IPv4 Settings

IP Network Setting DHCP Static IP

IP Address 192.168.10.51

Subnet Mask 255.255.255.0

Gateway 192.168.10.1

Primary DNS 192.168.10.1

Secondary DNS 0.0.0.0

- In **Step 18**, under the **MAC Address** section, click the **Mode** drop-down list and select **Enable**. In the fields provided, enter the 5GHz WiFi MAC address of **TEW-841APBO #1** and click **Save** at the bottom of the page.

Caution: NAWDS is enabled, please assign the Channel on both frequency bands manually for settings to take effect.

MAC Address	Mode
00 : 11 : 22 : 33 : 44 : 00	Enable
: : : : : :	Disable

MAKE SURE THE CHANGES TO THE CONFIGURATIONS ARE APPLIED

- The page should now have two indicators regarding pending changes:

- Top right menu of the page:

Changes: 4

Waiting for changes to be applied (4)

Apply

Revert

- Bottom right of the page:

Note: Settings configured on the Access Point are not applied until you click apply changes. In order to minimize time spent waiting for the Access Point to reboot when applying settings, we recommend configuring all necessary settings and changes prior to apply & reboot of the device.

Confirm Connectivity

1. Leave your computer connected to TEW-841APBO #2 and keep the access point management page open.
2. Make sure both TEW-841APBO #1 and TEW-841APBO #2 access point are powered on and approximately 15 ft. (5 m) apart from one another.

TEW-841APBO #1

TEW-841APBO #2

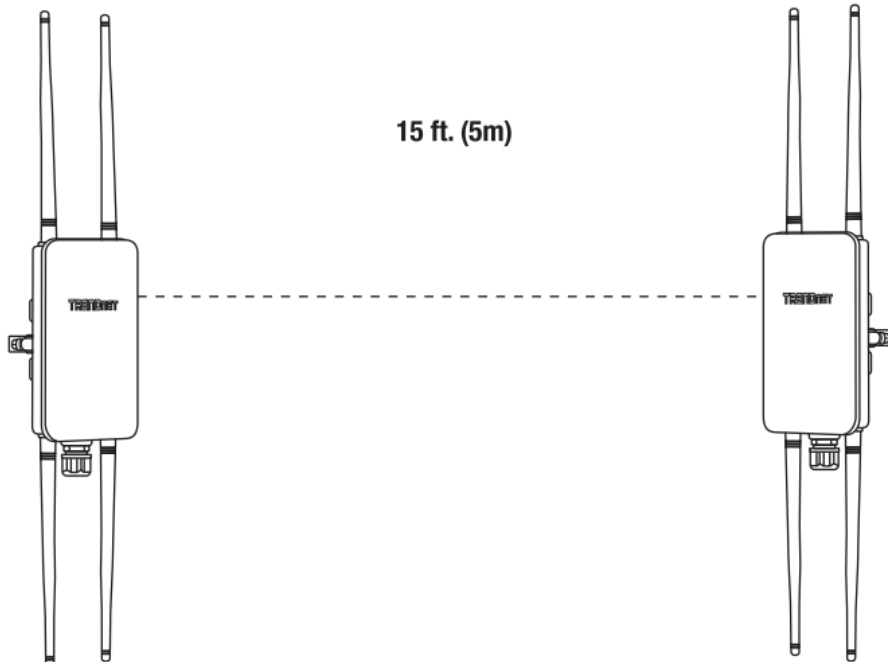

3. To verify connectivity, in the TEW-841APBO #2 access point management page, Click on the **Tools** tab under **Management** category in the left hand menu.

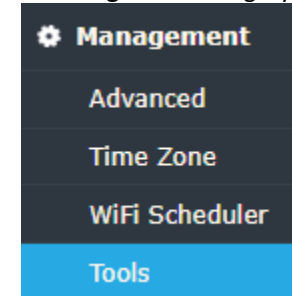

4. The first tab, **Ping**, will automatically be selected. In the **Target IP/Domain Name** field, enter the IP address **192.168.10.50**. Then click **Ping**. The first tab, **Ping**, will automatically be selected. In the **Target IP/Domain Name** field, enter the IP address **192.168.10.50**. Then click **Ping**.
5. Ping replies and 0% packet loss will indicate a successful WDS point to point bridge has been established between the two access points as shown below.

Ping Test Parameters

Target IP / Domain Name	<input type="text" value="192.168.10.50"/>
Ping Packet Size	<input type="text" value="64"/> Bytes
Number of Pings	<input type="text" value="4"/>

Start

```

PING 192.168.10.50 (192.168.10.50): 64 data bytes
72 bytes from 192.168.10.50: seq=0 ttl=64 time=4.221 ms
72 bytes from 192.168.10.50: seq=1 ttl=64 time=4.010 ms
72 bytes from 192.168.10.50: seq=2 ttl=64 time=3.008 ms
72 bytes from 192.168.10.50: seq=3 ttl=64 time=2.841 ms

--- 192.168.10.50 ping statistics ---
4 packets transmitted, 4 packets received, 0% packet loss
round-trip min/avg/max = 2.841/3.519/4.221 ms
  
```

6. You can also check the status of the wireless point to point bridge between the two access points in the **Connections** tab under **Overview** category in the left hand menu.

Note: If the connectivity test fails, wait for about 1 minute and try again. Make sure there are no obstacles between two access points and that they are not too close together.

Completed Installation Reference

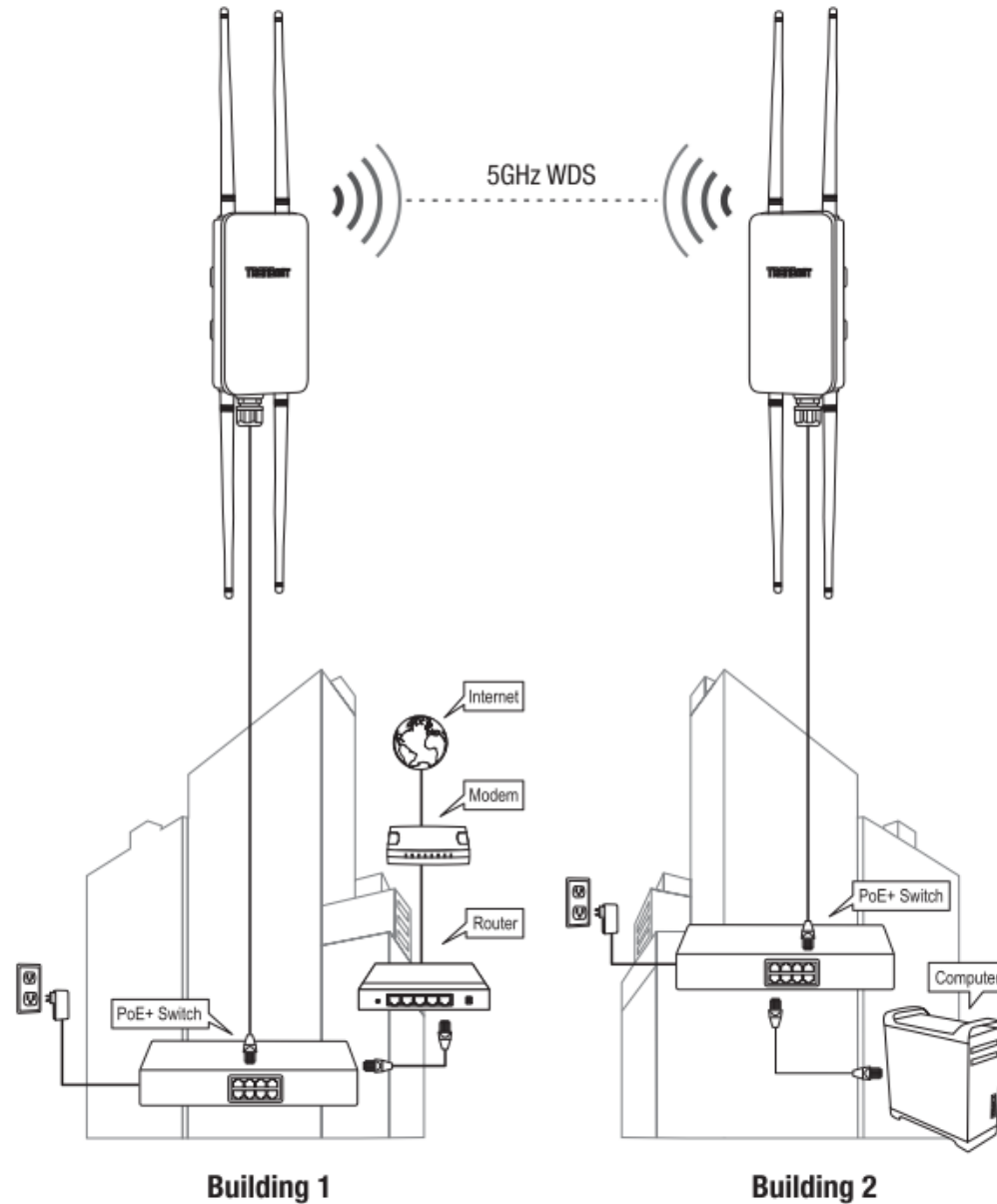

Hardware and Mounting Installation

Waterproof Kit Installation

1. Unscrew the sealing nut from the main body and remove the placeholder center pin.
2. Separate the rubber seal from the claw.
3. Verify that you have the following parts:



4. Insert one end of an Ethernet cable into the sealing nut.

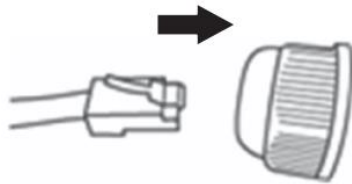

5. Insert the Ethernet cable into the seal.

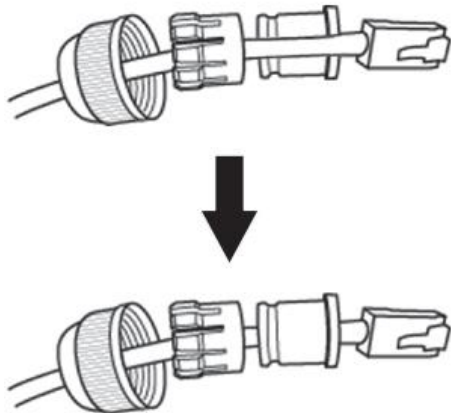

6. Insert the seal into the claw.

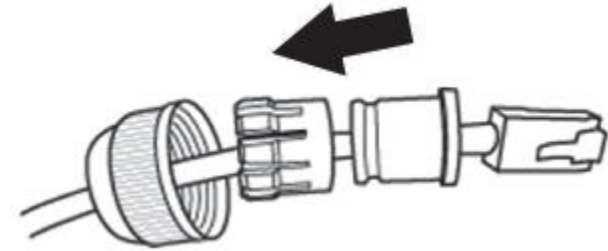

7. Insert the seal+rubber claw into the Cable Gland.

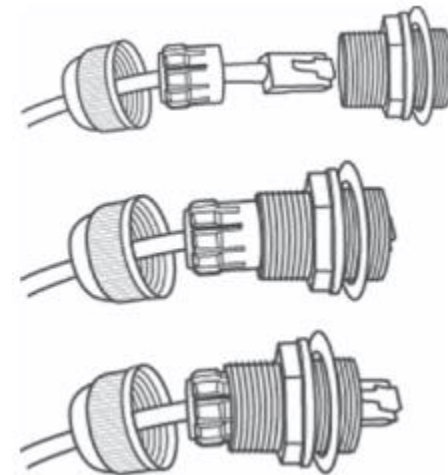

8. Connect the Ethernet cable to the LAN (PoE) port on the bottom of the access point.

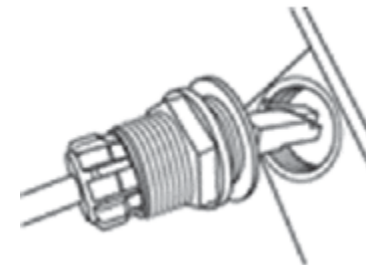

- By hand, screw the main body of the seal counter clockwise to secure it to the access point.

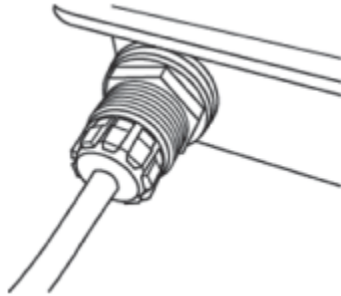

- By hand, screw the seal nut clockwise to secure it to the main body.



Pole Mount Installation

Note: The pole mounting clamp supports poles with a maximum diameter of 66 mm (2.63 in.)

- Insert the included pole mounting clamp through the hole located in the back of the access point.
- Wrap the clamp around the pole where the access point will be installed and secure by turning the pole clamp screw clockwise at the desired height and position.

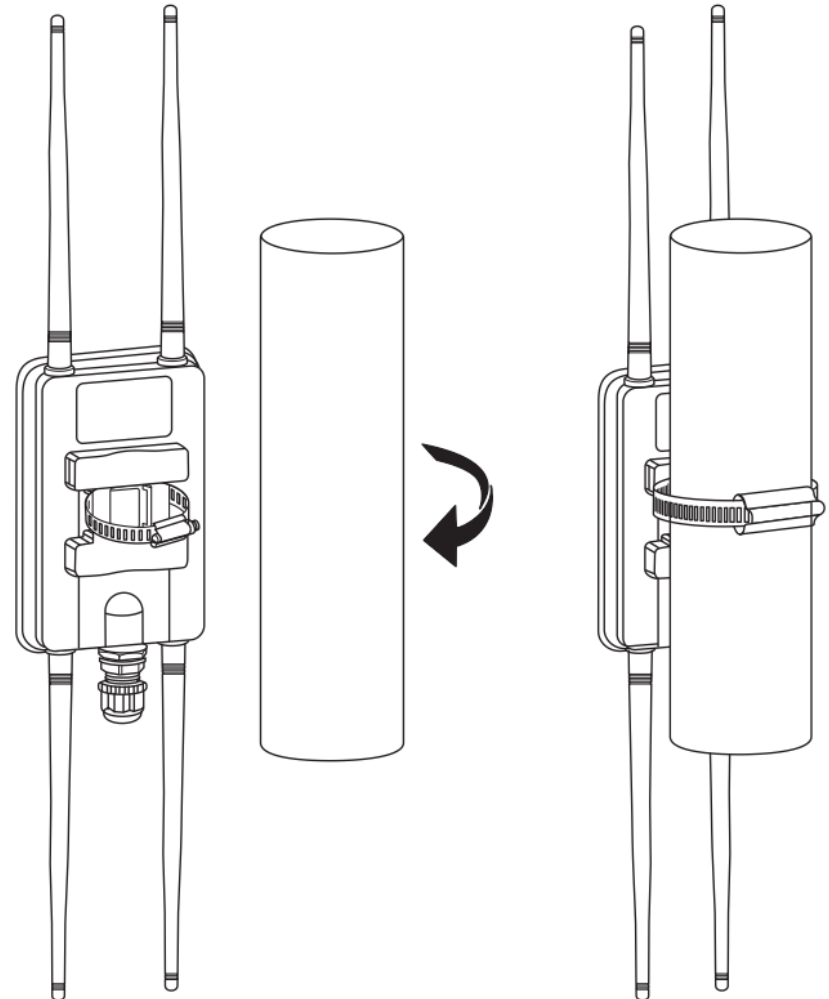

Application Modes

Although the access point is intended to be used for primarily WDS point-to-point bridging, the access point offers other operating modes. The access point's multiple mode system can be configured either in client bridge mode or as an access point. It also can be used as a WDS (Wireless Distribution System) node for Ethernet network expansion. This section explains the different modes the device has available, **Access Point (AP)**, **Client Bridge**, **WDS Access Point**, **WDS Station**, and **WDS Bridge**.

The different operation modes can be found under **Network > Wireless > Operation Mode** in the access point web management page.

Note: The model used in the artwork below may appear different than your unit.

Access Point (AP)

An **access point** can be either a main, relay or remote base station. A main base station is typically connected to a wired network via an Ethernet port. A relay base station relays data between main base stations and relay stations or remote base stations with clients. A remote base station is the end point to accept connections from wireless clients and pass data upstream to a network wirelessly.

Example: Access Point

- It can be deployed as a traditional fixed wireless access point.

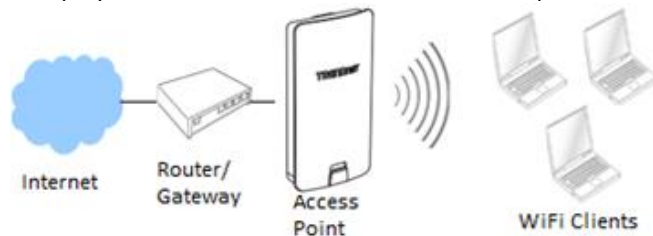

Client Bridge

Client bridge mode enables the device to essentially act as a wireless client while bridging with the LAN port on the device. In this mode, the AP functions similarly to that of a wireless client or station such as mobile phone, tablet, or notebook computer. The wired port LAN (PoE) is logically bridged to the wireless interface. The clients of the remote access point are in the same subnet from Main Base.

Example: AP with Client Bridge mode

- It can be deployed as a wireless client (with wired LAN) to a wireless access point.



WDS Access Point (WiFi Distribution System)

WDS Access Point mode (also known as **WDS AP + Client Bridge** mode) allows the unit to broadcast a publically visible WiFi Network with a WDS backbone simultaneously bridged to another WDS AP or WDS Bridge. With the LAN (PoE) port logically bridged to the wireless interface, the wired and wireless clients of the access point will be in the same subnet from Main Base Station.

Note: Each TEW-841APBO in WDS Access Point mode can establish a WDS network with up to **8 other** access points **per radio**.

Example: 2x WDS Access Point

- It can be deployed as a traditional fixed wireless access point and establish WDS bridging to an upstream access point to expand a network.



WDS Station

In **WDS Station** mode (also known as **WDS Client Bridge** mode), the device acts as a client to any standard wireless connection with the LAN (PoE) port logically bridged to the wireless interface, allowing the clients of the device to be in the same subnet as those from Main Base Station. The main advantage of WDS Station compared to Client Bridge mode is WDS station additionally ensures the integrity of WDS link in terms of MAC address transparency, allowing for daisy chained networking. Each WDS AP can sustain as many WDS Station connections as needed due to the WDS Stations not needing WDS Link Settings and are not limited by MAC addresses in WDS Link protocols.

Example: WDS Access Point with 2 WDS Stations

- It can be deployed as a WDS Station bridging to an upstream access point to expand a network. Due to the MAC transparency and no maximum number of WDS Links, it can be daisy-chained and also support point-to-multipoint installations.

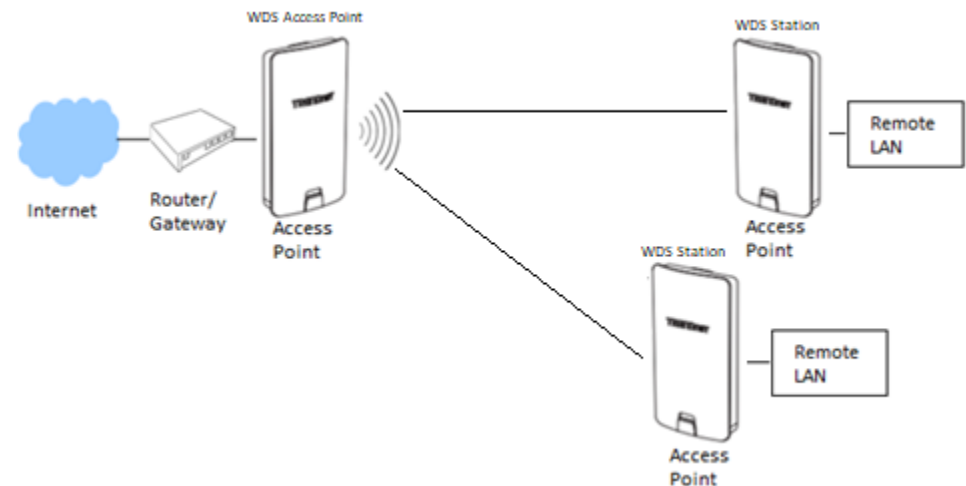

WDS Bridge

This is the primary application mode for WDS connections within the networking industry. The high gain Omni-directional antenna makes this access point an ideal solution for establishing WDS point-to-multipoint wireless bridges or links between multiple physical locations that are a great distance from one another.

Note: Each TEW-841APBO in WDS Bridge mode can establish a WDS network with up to **8 other** access points **per radio**.

Example 1: Point-to-Point



Example 2 : Point-to-Multi-Point

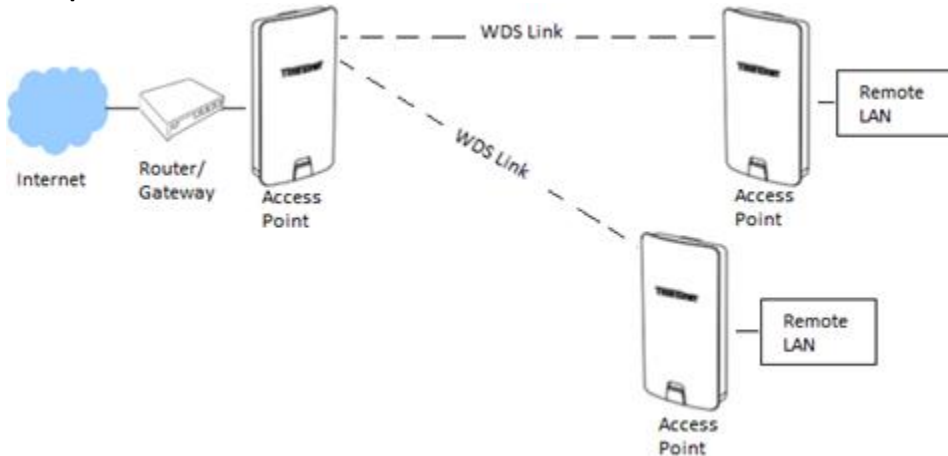

Accessing your access point management page

Access your access point management page

Note: Make sure your access point is powered on using an IEEE 802.3at PoE+ switch or injector and your computer is connected to the same network as that switch or injector. Using your Internet web browser (e.g. Internet Explorer®, Firefox®, Chrome™, Safari®, Opera™), your AP's management page may be accessed at its domain name registration <http://tew-841apbo>, default IP address <http://192.168.10.100> (when no DHCP server present), or the IP address assigned by your DHCP server. The TEW-841APBO by default is configured with DHCP IP settings. Additionally, this information is printed on the wireless sticker and device label located on the back of the access point enclosure.

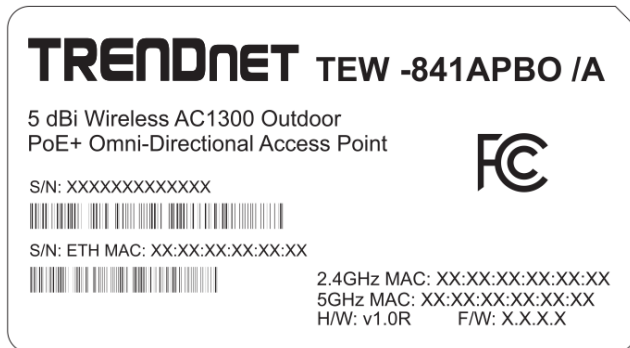
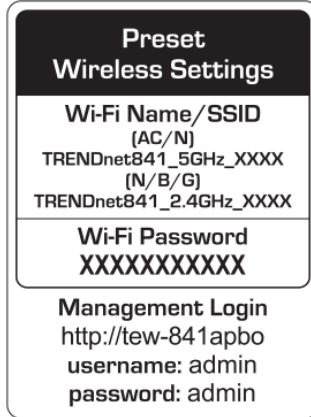

If the access point is connected to a network with an active DHCP server, the access point will be assigned an IP address by your DHCP server. Check your DHCP server's client list for the assigned IP address.

If the initial configuration of the access point is done on an isolated network, the default IP address is <http://192.168.10.100>. Assign a static IP address to your computer's network adapter in the subnet of 192.168.10.x (e.g. 192.168.10.10) and subnet mask of 255.255.255.0.

If you have changed the default IP address, you will need to ensure that your computer is configured with IP address settings in the same subnet as the as the access point in order to access the management page. (Ex. Access Point IP address changed to 192.168.0.100 / 255.255.255.0, example computer address 192.168.0.25 / 255.255.255.0).

Alternatively, you may also use the default domain name <http://tew-841apbo>.

1. Open your web browser and go to the address <http://192.168.10.100>, <http://tew-841apbo>, or the IP address that has been assigned to the access point. Your access point will then prompt you for a user name and password.



2. By default, the user name is *admin* and password is *admin*. Enter your **Username** and **Password**, then click **Login**.

Note: If you have changed the password, you will need to login using the new password. *User Name and Password are case sensitive.*

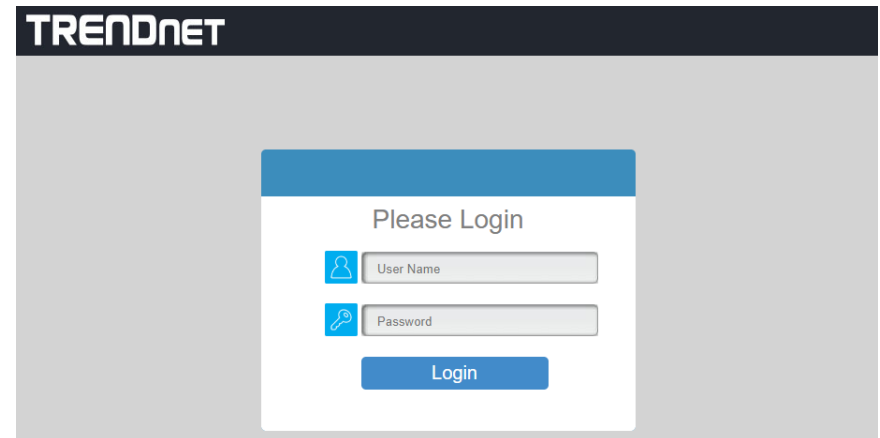

Overview

Device Status

Overview > Device Status

This page will display the AP system summary information such as the device name, serial number, system time, firmware version, MAC, IPv4/IPv6 address settings, WiFi information, etc.

1. Log into your access point management page (see "[Access your access point management page](#)" on page 27).
2. Click on **Device Status** from the left side menu. To refresh the page, click **Refresh** at the bottom of the page.

Device Information

- **Device Name** – Displays the identifying device name of your access point. This information can be modified under the **Network > Wireless** section.
- **Serial Number** – Displays the serial number assigned during manufacturing process.
- **MAC Address**– Displays the MAC address for the access point's LAN, and both WLAN radios.
- **Country** – Displays the country of the access point
- **Current Local Time** – Displays the current time assigned to the access point. This information can be modified under the **Management > Time Zone** section.
- **Uptime** – Displays the time the access point has been powered on.
- **Firmware Version** – Displays the current firmware of the access point
- **Management VLAN ID** – Displays the currently VLAN ID status.

Device Information

Device Name	TEW-841APBO
Serial Number	EP9G8A1000001
MAC Address	
- LAN	3C:8C:F8:FD:04:12
- Wireless LAN - 2.4GHz	3C:8C:F8:FD:04:13
- Wireless LAN - 5GHz	3C:8C:F8:FD:04:14
Country	USA
Current Local Time	Fri Sep 13 23:59:42 2019
Uptime	2d 23h 33m 2s
Firmware Version	v1.0.0.10
Management VLAN ID	Untagged

Memory Information

- This section displays the access point's memory or RAM usage status.

Memory Information

Total Available	76664 kB / 126316 kB (60%)
Free	44052 kB / 126316 kB (34%)
Cached	24436 kB / 126316 kB (19%)
Buffered	8176 kB / 126316 kB (6%)

LAN Information IPv4

- **IP Address** – Displays the IPv4 address assigned to the access point. This can be modified under the **Network > Basic** section.
- **Subnet Mask** – Displays the current IPv4 subnet mask assigned to your access point.
- **Gateway** – Displays the current gateway address assigned to your access point.
- **Primary DNS** – Displays the primary Domain Name Server (DNS) assigned to your access point.
- **Secondary DNS** – Displays the secondary Domain Name Server (DNS) assigned to your access point.
- **DHCP Client** – Displays the status of the DHCP client.
- **Spanning Tree Protocol (STP)** – Displays the status of the STP.

LAN Information - IPv4

IP Address	192.168.14.111
Subnet Mask	255.255.255.0
Gateway	192.168.14.44
Primary DNS	192.168.14.44
Secondary DNS	N/A
DHCP Client	Enable
Spanning Tree Protocol(STP)	Disable

LAN Information IPv6

- **IP Address** – Displays the IPv6 address assigned to the access point. This can be modified under the **Network > Basic** section.
- **Link-Local Address** – Displays the current Link-Local address and prefix length assigned to your access point.
- **Gateway** – Displays the current gateway address assigned to your access point.
- **Primary DNS** – Displays the primary Domain Name Server (DNS) assigned to your access point.
- **Secondary DNS** – Displays the secondary Domain Name Server (DNS) assigned to your access point.

LAN Information - IPv6

IP Address	2600:8802:6700:b74:3e8c:f8ff:febd:b4e4
Link-Local Address	fe80::3e8c:f8ff:febd:b4e4
Gateway	fe80::3e8c:f8ff:febd:b4e4
Primary DNS	N/A
Secondary DNS	N/A

Wireless LAN Information – 2.4GHz

- **Operation Mode** – Displays the operation mode that the access point is currently set.
- **Wireless Mode** – Displays the IEEE 802.11 protocol the access point's wireless radio is broadcasting on.
- **Channel Bandwidth** – Displays the bandwidth (in MHz) that the access point's radio is using
- **Channel** – Displays the channel that the 2.4GHz radio is using.
- **Distance** – Displays the distance (coverage/radius) in meters that the access point is to cover.

Wireless LAN Information - 2.4GHz

Operation Mode	Access Point
Wireless Mode	802.11 B/G/N
Channel Bandwidth	20 MHz
Channel	2.437 GHz(Channel 6)
Distance	1000 M

Wireless LAN Information – 5GHz

- **Operation Mode** – Displays the operation mode that the access point is currently set.
- **Wireless Mode** – Displays the IEEE 802.11 protocol the access point's wireless radio is broadcasting on.
- **Channel Bandwidth** – Displays the bandwidth (in MHz) that the access point's radio is using
- **Channel** – Displays the channel that the 5GHz radio is using.
- **Distance** – Displays the distance (coverage/radius) in meters that the access point is to cover.

Wireless LAN Information - 5GHz

Operation Mode	Access Point
Wireless Mode	802.11 N/AC
Channel Bandwidth	80 MHz
Channel	5.805 GHz(Channel 161)
Distance	1000 M

Statistics

- **Profile** – Displays the wireless profile number.
- **SSID** – Displays the SSID name of the profile.
- **Security** – Displays the type of security configured for the profile.
- **VID** – Displays the VID assigned to this profile.
- **802.1Q** – Displays the status of 802.1Q.
- **RX(Packets)** – Displays the data usage when receiving data (in Bytes) and number of packets.
- **TX(Packets)** – Displays the data usage when transmitting data (in Bytes) and number of packets.

Statistics - Access Point 2.4GHz/5GHz

Profile	SSID	Security	VID	802.1Q	RX(Packets)	TX(Packets)
#1	TRENDnet841_2.4GHz_0...	WPA2/PSK AES	-	Disable	0.00 B(0 Pkts.)	30.40 MB(0 Pkts.)
#2	TRENDnet841_5GHz_0413	WPA2/PSK AES	-	Disable	0.00 B(0 Pkts.)	30.40 MB(0 Pkts.)

3. Click **Refresh** at the bottom of the page to refresh the page.



Connections

Overview > Connections

This page will display all active connections that have been established with the access point.

1. Log into your access point management page (see "[Access your access point management page](#)" on page 27).
2. Click on **Connections** from the left side menu. To kick a client connection, click **Kick** to the right of the listing. To refresh the page, click **Refresh** at the bottom of the page.
 - **WDS Link List** – Displays connections established when using **WDS AP** or **WDS Bridge**.
 - **Connection List** – Display all other wireless connections.

Note: The following images are sample images of a few different operation modes. For more information regarding operation modes, please see "[Application Mode](#)" on page 24.

Connection List - 2.4GHz

SSID	MAC Address	TX (KB)	RX (KB)	RSSI (dBm)	Block
------	-------------	---------	---------	------------	-------

WDS Link List - 5GHz

WDS Link ID#	MAC Address	Link Status	RSSI(dBm)
--------------	-------------	-------------	-----------

Connection List - 5GHz

SSID	MAC Address	TX	RX	RSSI	Block
TRENDnet840_B4E5	3c:8c:f8:fd:b4:e7	42 KB	32 KB	-44dBm	Kick

Real-time

Overview > Real-time

This page displays CPU Load and Traffic utilization of the access point in Real-time.

1. Log into your access point management page (see "[Access your access point management page](#)" on page 27).
2. Click on **Real-time** from the left side menu.
 - **Load** – Displays the CPU usage %.
 - **Traffic** – Display the traffic data broken down per configured interface of the access point.

Realtime Traffic (KB/s)

TRENDnet841_2.4GHz_0413 TRENDnet841_5GHz_0413 LAN

2.4G:

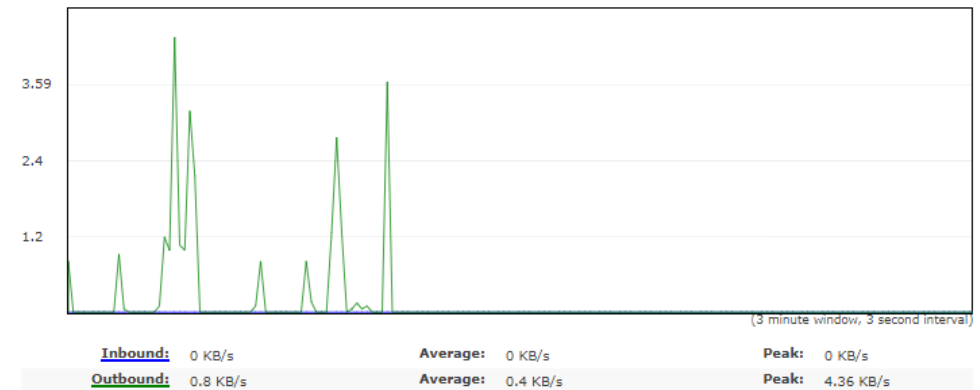

Network

Basic

Network > Basic

This page allows configuration of the access point's IPv4, IPv6, and Spanning Tree Protocol settings.

1. Log into your access point management page (see "[Access your access point management page](#)" on page 27).
2. Click on **Basic** under **Network** from the left side menu. Please note, when clicking **Save**, the settings are saved but not applied yet.

IPv4 Settings

- **IP Network Setting** – Select either **DHCP** or **Static IP**. *Default: DHCP*
- **IP Address** – Enter the desired IPv4 address if above setting is set to static IP.
- **Subnet Mask** – Enter the desired IPv4 subnet mask.
- **Gateway** – Enter the desired IPv4 Gateway.
- **Primary DNS** – Enter the desired primary Domain Name Server (DNS).
- **Secondary DNS** – Enter the desired secondary Domain Name Server (DNS).

IPv4 Settings

IP Network Setting	<input type="radio"/> DHCP <input checked="" type="radio"/> Static IP
IP Address	<input type="text" value="192.168.10.50"/>
Subnet Mask	<input type="text" value="255.255.255.0"/>
Gateway	<input type="text" value="192.168.10.1"/>
Primary DNS	<input type="text" value="192.168.10.1"/>
Secondary DNS	<input type="text" value="0.0.0.0"/>

IPv6 Settings

- **Link-local Address** – Check the box to enable IPv6 Link-local Address setting.
- **IP Address** – Enter the desired IPv6 address.
- **Subnet Prefix Length** – Enter the desired IPv6 subnet prefix length.
- **Gateway** – Enter the desired IPv6 Gateway.
- **Primary DNS** – Enter the desired primary Domain Name Server (DNS).
- **Secondary DNS** – Enter the desired secondary Domain Name Server (DNS).

IPv6 Settings

Link-local Address

IP Address	<input type="text"/>
Subnet Prefix Length	<input type="text"/>
Gateway	<input type="text"/>
Primary DNS	<input type="text"/>
Secondary DNS	<input type="text"/>

Spanning Tree Protocol (STP) Settings

- **Status** – Select either to **Enable** or **Disable** STP. *Default: Disabled*
- **Hello Time** – Enter the desired hello time (in seconds)
- **Max Age** – Enter the desired max age (in seconds).
- **Forward Delay** – Enter the desired forward delay (in seconds).
- **Priority** – Enter the desired priority of this STP configuration.



Spanning Tree Protocol (STP) Settings

Status	<input type="radio"/> Enable <input checked="" type="radio"/> Disable
Hello Time	<input type="text" value="2"/> seconds (1-10)
Max Age	<input type="text" value="20"/> seconds (6-40)
Forward Delay	<input type="text" value="15"/> seconds (4-30)
Priority	<input type="text" value="32768"/> (0-65535)

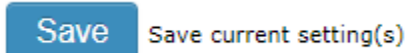
- Click **Save** at the bottom of the page to save your settings.

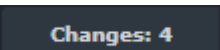

MAKE SURE THE CHANGES TO THE CONFIGURATIONS ARE APPLIED

- Click **Changes**  from the top right menu bar, and click **Apply** .

OR

- Click **Apply**  on the bottom right of any page:

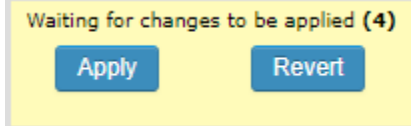

Wireless

Network > Wireless

This page allows configuration of all wireless settings of the access point.

For more information on the differences between the modes, see "[Application Mode](#)" on page 24.

- Log into your access point management page (see "[Access your access point management page](#)" on page 27).
- Click on **Wireless** under **Network** from the left side menu. Please note, when clicking **Save**, the settings are saved but not applied yet.

Wireless Settings

- Device Name** – Enter the desired name for this device. If changing the name.

Wireless Settings	
Device Name	TEW-841APBO

2.4GHz | 5GHz

Note: The following section will have different options based on chosen Operation Mode of the access point.

	2.4GHz	5GHz
Operation Mode	Access Point	Access Point
Wireless Mode	802.11 B/G/N	802.11 AC/N
Channel HT Mode	20MHz	80MHz(AC Only)
Channel	Configuration	
Transmit Power	Auto	Auto
Bit Rate	Configuration	
Client Limits	<input checked="" type="radio"/> Enable <input type="radio"/> Disable 127	<input checked="" type="radio"/> Enable <input type="radio"/> Disable 127
Multicast to Unicast Stream Conversion	<input checked="" type="radio"/> Enable <input type="radio"/> Disable	
AP Detection	Scan	
Distance (0-30km)	1 (0.6miles)	1 (0.6miles)

- **Operation Mode** – Select the desired operation mode for each radio from the drop down, **Access Point, Client Bridge, WDS Access Point, WDS Station, or WDS Bridge**. For more information, see “[Application Mode](#)” on page 24.
- **Wireless Mode** – Displays the IEEE standard per radio.
- **Channel HT Mode** – Select the desired channel HT mode per radio from the dropdown; **80MHz(AC Only), 40MHz, or 20MHz**.
- **Channel** – Click **Configuration**, and select the channel from the pop-up window. **GREY options are selected, and BLUE options are not selected**. Click **Save** to save the channel and close the pop-up. *The following image is an example of 5GHz channel selection window. ****if the pop-up window does not appear, please disable the browser’s ad/pop-up blocker*****

5GHz

All	None
U-NII-1	U-NII-3
Ch 36 : 5.180 GHz	Ch 40 : 5.200 GHz
Ch 44 : 5.220 GHz	Ch 48 : 5.240 GHz
Ch149 : 5.745 GHz	Ch153 : 5.765 GHz
Ch157 : 5.785 GHz	Ch161 : 5.805 GHz

Save Save current setting(s)

- **Transmit Power** – Select the desired transmit power from the dropdown.
- **Bit Rate** – Click **Configuration**, and select the bitrate using the slider in the pop-up window. Click **Save** to save the setting and close the pop-up ****if the pop-up window does not appear, please disable the browser’s ad/pop-up blocker****

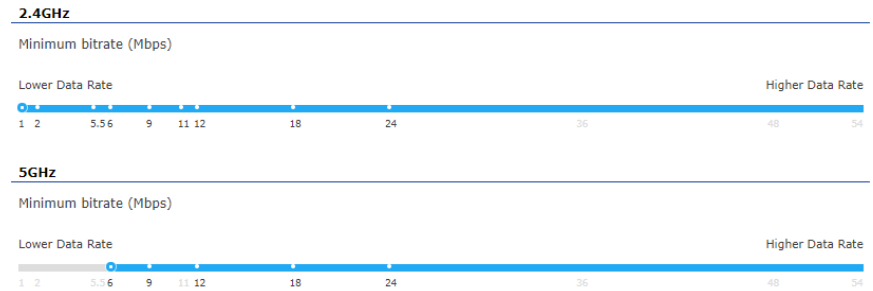

- **Client Limits** – Enter the desired number of maximum clients and select **Enable/Disable**
- **Multicast to Unicast Stream Conversion** – Select **Enable** to enable this feature, and **Disable** to disable the feature.
 - Unicast conversion method allows a WLAN AP to have a direct relationship with each client to transmit original multicast-like traffics on a one-to-one basis, establishing individual sessions between the transmission server and each client. This method will add additional bandwidth overhead on the unicast server upon each additional client.
 - Multicast transmission is a one-to-many group communication methodology in which a WLAN AP forwards all broadcast traffics from a multicast source to a client subnet where multiple client devices are listening.
- **AP Detection** – Click **Scan** to commence a network site survey of the surrounding access points.
- **Distance** – Enter in the distance (0-30 in km), as in the coverage radius. The equivalent distance measured in miles is to the right of the field for your convenience.

Wireless Settings – Access Point / WDS Access Point

Note: The following section configures wireless radios that are set to **Access Point** and **WDS Access Point** operation mode. WDS AP mode may not have all configurations available.

For Access Point and WDS Access Point modes:

- **Enabled** – Check the box to **enable** this wireless radio. Deselected box indicates radio is off.
- **SSID** – The SSID of the radio.
- **2.4GHz** – Check the box to apply this wireless profile to the 2.4GHz wireless radio.
- **5GHz** – Check the box to apply this wireless profile to the 5GHz wireless radio.
- **Edit** – To edit the advanced wireless settings, click **Edit**. Clicking **Save** in the pop-up window will return to the previous page. ***if the pop-up window does not appear, please disable the browser's ad/pop-up blocker***
- **Security** – Displays the security type assigned to this SSID.
- **Guest Network** – Check the box to turn this profile into a guest network with its configurable subnet and DHCP server.
- **VLAN ID** – This displays the VLAN ID or VID of this profile, if one has been assigned.

Wireless Settings - Access Point

Enabled	SSID	2.4GHz	5GHz	Edit	Security	Guest Network	VLAN ID
<input checked="" type="checkbox"/>	TRENDnet841_2.4GHz_04	<input checked="" type="checkbox"/>	<input type="checkbox"/>	Edit	WPA2/PSK AES	<input type="checkbox"/>	-
<input checked="" type="checkbox"/>	TRENDnet841_5GHz_0413	<input type="checkbox"/>	<input checked="" type="checkbox"/>	Edit	WPA2/PSK AES	<input type="checkbox"/>	-
<input type="checkbox"/>	TRENDnet841_0413_3	<input type="checkbox"/>	<input type="checkbox"/>	Edit	WPA2/PSK AES	<input type="checkbox"/>	-
<input type="checkbox"/>	TRENDnet841_0413_4	<input type="checkbox"/>	<input type="checkbox"/>	Edit	WPA2/PSK AES	<input type="checkbox"/>	-
<input type="checkbox"/>	TRENDnet841_0413_5	<input type="checkbox"/>	<input type="checkbox"/>	Edit	WPA2/PSK AES	<input type="checkbox"/>	-
<input type="checkbox"/>	TRENDnet841_0413_6	<input type="checkbox"/>	<input type="checkbox"/>	Edit	WPA2/PSK AES	<input type="checkbox"/>	-
<input type="checkbox"/>	TRENDnet841_0413_7	<input type="checkbox"/>	<input type="checkbox"/>	Edit	WPA2/PSK AES	<input type="checkbox"/>	-
<input type="checkbox"/>	TRENDnet841_0413_8	<input type="checkbox"/>	<input type="checkbox"/>	Edit	WPA2/PSK AES	<input type="checkbox"/>	-

Clicking **Edit** from above, **Wireless Settings – Access Point** opens up the advanced configuration options. Be sure to click **Save** prior to returning to the previous page.

Wireless Setting – Access Point 2.4GHz/5GHz

- **Enable** – Check the box next to the radio to apply this wireless profile to.
- **SSID** – Enter the SSID you would like to assign to this wireless profile.
- **Hidden SSID** – Select **Enable** to hide this SSID name from broadcasting.
- **Client Isolation** – Select **Enable** to block communication between associated clients under the same WLAN.
- **VLAN Isolation** – When this option is enabled with a specified VLAN ID in the SSID profile, all traffic associated with this SSID will be tagged with this VLAN ID upon entering the LAN Bridge.
- **L2 Isolation** – Check the box to isolate on a layer-2 basis.

Wireless Setting - Access Point 2.4GHz/5GHz

Enable 2.4G 5G

SSID

Hidden SSID Enable Disable

Client Isolation Enable Disable

VLAN Isolation Enable Disable
ID: (1-4094)

L2 Isolation Enable Disable

Band Steering

- **Status** – Select **Enable** to enable the band steering feature. Band steering facilitates effective spectrum usage, enabling 5GHz capable clients to associate with this AP's 5GHz radio, thus offloading bandwidth utilization in 2.4GHz band.
- **Band Steering** – Click the dropdown to select the aggressiveness of the steering. Band steering f
 - **Prefer 5GHz** – Enter an RSSI signal strength value. When the connection drops below the value, the client will be moved over to the 2.4GHz band. (the more negative the number, the lower the signal strength. ex: -40dBm is significantly stronger than -80.
 - **Force 5GHz** – This option causes all 5GHz capable clients to connect to the 5GHz radio.
 - **Band Balance** – Similar to the **Prefer 5GHz** option, but additionally allows configuration of percentage of new clients on the 5GHz.

Band Steering

Status Enable Disable

Band Steering Prefer 5GHz

5GHz RSSI dBm

NOTE: In order for Band Steering function to work properly, both 2.4GHz and 5GHz SSID and Security Settings must be the same.

Wireless Security

- **Security Mode** – Select the mode from the dropdown menu.
- **Encryption** – Select the mode from the dropdown menu.
- **Passphrase** – Enter the Wi-Fi passphrase in this field.
- **Group Key Update Interval** – Enter the time between group key updates.

Wireless Security

Security Mode	WPA2-PSK
Encryption	AES
Passphrase	841A1000001
Group Key Update Interval	3600 (30~3600; 0:Disable)

Radius Settings

- **NAS-ID** – Check the box, and enter the ID/name of the server.
- **NAS-PORT** – Check the box, and enter the port number of the server.
- **NAS-IP** – Check the box, and enter the IP address of the server.

Radius Settings

<input type="checkbox"/> NAS-ID	
<input type="checkbox"/> NAS-PORT	(0 ~ 65535)
<input type="checkbox"/> NAS-IP	

Radius Accounting

- **Radius Accounting** – Select **Enable** to enable radius accounting feature.
- **Radius Accounting Server** – Enter the address of your radius accounting server.
- **Radius Accounting Port** – Enter the port of your radius accounting server.
- **Radius Accounting Secret** – Enter the secret key for your radius server.
- **Interim Accounting Interval** – Enter the interval (in seconds).

Radius Accounting

Radius Accounting	<input checked="" type="radio"/> Enable <input type="radio"/> Disable
Radius Accounting Server	
Radius Accounting Port	1813
Radius Accounting Secret	
Interim Accounting Interval	600

Fast Roaming

- **Status** – Select **Enable** to enable fast roaming for supported clients, across access point's under the same ESS WLAN. This option is available when selecting WPA2-PSK, WPA2-Enterprise as the security mode.

Fast Roaming ⓘ

Status Enable Disable

Wireless MAC Filter

- **ACL Mode** – Select from the ACL dropdown to allow or deny, and enter in the **MAC Address** below, then click **Add**.

Wireless MAC Filter

ACL Mode	Disabled
No.	MAC Address

Wireless Traffic Shaping

- **Wireless Traffic Shaping** – Select **Enable** to enable this feature. Enter in the desired limits and check the box if the limit is to be applied per client rather than the whole radio.

Wireless Traffic Shaping

Status	<input checked="" type="radio"/> Enable <input type="radio"/> Disable
Download Limit	0 Mbps (1-999) <input type="checkbox"/> Per User
Upload Limit	0 Mbps (1-999) <input type="checkbox"/> Per User

Save – Clicking **Save** will close the pop-up window and return to the previous page. Remember to save your advanced configurations!

Guest Network DHCP Server Settings

- Guest networks can have their own DHCP server. The guest DHCP server is shared across all guest networks.
- **Manual IP Settings**
 - **IP Address** – Enter the IP address to assign as the “Gateway” for this guest SSID.
 - **Subnet Mask** – Enter the subnet mask for the “Gateway” for this guest SSID.
- **Automatic DHCP Server Settings**
 - **Starting IP Address** – Enter the starting IP address in the DHCP range to be assigned for this guest network.
 - **Ending IP Address** – Enter the starting IP address in the DHCP range to be assigned for this guest network.
 - **WINS Server IP** – Enter the IP address for the external WINS Server for name resolution.

Guest Network DHCP Server Settings

Manual IP Settings	
- IP Address	192.168.200.1
- Subnet Mask	255.255.255.0
Automatic DHCP Server Settings	
- Starting IP Address	192.168.200.100
- Ending IP Address	192.168.200.200
- WINS Server IP	0.0.0.0

Wireless Settings – Client Bridge and WDS Station modes:

Wireless Settings - 2.4GHz

SSID	Edit	Security
AP SSID	Edit	None

- **SSID** – Displays the SSID that this device is configured to be connected to.
- **Edit** – Click **Edit** to modify settings. ***if the pop-up window does not appear, please disable the browser's ad/pop-up blocker***
 - **Preferred BSSID** - Enter the MAC address, or click device discovery.
 - **Wireless Security** – Select and enter in the security settings for the SSID you are trying to connect to.
 - **Save** – Click **Save** to return to the previous page.

Wireless Setting - 5GHz

Preferred BSSID : : : : : [Device Discovery](#)

SSID

Wireless Security - 5GHz

Security Mode

[Save](#) Save current setting(s)

WDS Link Settings:

Note: This access point can establish 8 WDS links per radio, for 16 WDS links total.

- **Security** – Select and enter the security settings used for the WDS link.
- **MAC Address** – Enter the MAC address for the WDS link and select **Enable**.

WDS Link Settings - 5GHz

Security

WEP Key 40/64-bit(10 hex digits)

AES Passphrase (8-63 ASCII characters or 64 hexadecimal digits)

MAC Address	Mode
<input type="text"/> : <input type="text"/> : <input type="text"/> : <input type="text"/> : <input type="text"/> : <input type="text"/>	<input type="text" value="Disable"/>
<input type="text"/> : <input type="text"/> : <input type="text"/> : <input type="text"/> : <input type="text"/> : <input type="text"/>	<input type="text" value="Disable"/>
<input type="text"/> : <input type="text"/> : <input type="text"/> : <input type="text"/> : <input type="text"/> : <input type="text"/>	<input type="text" value="Disable"/>
<input type="text"/> : <input type="text"/> : <input type="text"/> : <input type="text"/> : <input type="text"/> : <input type="text"/>	<input type="text" value="Disable"/>
<input type="text"/> : <input type="text"/> : <input type="text"/> : <input type="text"/> : <input type="text"/> : <input type="text"/>	<input type="text" value="Disable"/>

RSSI Threshold

- **Status** – Select **Enable** to enable the RSSI threshold feature.
- **RSSI** – Enter the RSSI threshold to trigger the AP to encourage the client to switch to another AP with a stronger signal. The more negative the number, the weaker the signal strength. A “-100dBm” is essentially an empty signal strength.

RSSI Threshold	2.4GHz	5GHz
Status	<input type="radio"/> Enable <input checked="" type="radio"/> Disable	<input type="radio"/> Enable <input checked="" type="radio"/> Disable
RSSI (Range: -100dBm ~ -60dBm)	<input type="text" value="-90"/> dBm	<input type="text" value="-85"/> dBm

Caution: Enabling RSSI Threshold disassociates wireless clients that fall below the configured RSSI threshold and may cause wireless clients to reconnect frequently. It is recommended to disable this feature unless you deem it absolutely necessary.

Management VLAN Settings: When enabled with a specified VLAN ID, the device will only allow management interface access with the specified VLAN ID.

- **Status** – Select **Enable** to enable this feature then enter in the VLAN ID. .

Management VLAN Settings	
Status	<input type="radio"/> Enable <input checked="" type="radio"/> Disable
VLAN ID	<input type="text" value="4094"/>

Caution: If you encounter disconnection issue during the configuration process, verify that the switch and the DHCP server can support the new VLAN ID and then connect to the new IP address.

3. Click **Save** at the bottom of the page to save your settings.

Save Save current setting(s)

MAKE SURE THE CHANGES TO THE CONFIGURATIONS ARE APPLIED

- Click **Changes** **Changes: 4** from the top right menu bar, and click **Apply**.

OR

- Click **Apply** **Apply** on the bottom right of any page:

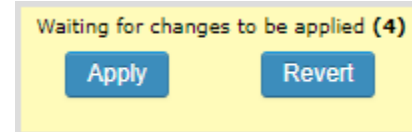

Management

Advanced

Management > Advanced

This page contains the SNMP, CLI, Telnet, SSH, and Email Alert configurations.

1. Log into your access point management page (see "[Access your access point management page](#)" on page 27).
2. Click on **Advanced** under **Management** from the left side menu.

SNMP Settings

- **Status** – Select **Enable** to enable SNMP. *Default: Disabled*
- **Contact** – Enter the **Contact** for the SNMP in this field.
- **Location** – Enter the **Location** for the SNMP in this field.
- **Port** – Enter the **Port** for the SNMP in this field.
- **Community Name (Read Only)** – Enter the community name designated with **Read Only** permissions.
- **Community Name (Read Write)** – Enter the community name designated with **Read Write** permissions.
- **Trap Destination**
 - **Port** – Enter the port number for the SNMP trap destination.
 - **IP Address** – Enter the IP address for the SNMP trap destination.
 - **Community Name** – Enter the community name for the SNMP trap destination (defined above).
- **SNMPv3 Settings**
 - **Status** – Select **Enable** to enable SNMPv3.
 - **Username** – Enter the username for the SNMPv3.
 - **Authorized Protocol** – Select the authorized protocol for the SNMPv3.
 - **Authorized Key** – Enter the key for the protocol specified above for SNMPv3.
 - **Private Protocol** – Select the private protocol for the SNMPv3.
 - **Private Key** – Enter the private key for the protocol specified above for SNMPv3.
 - **Engine ID** – Enter the engine ID.

SNMP Settings

Status	<input type="radio"/> Enable <input checked="" type="radio"/> Disable
Contact	<input type="text"/>
Location	<input type="text"/>
Port	<input type="text" value="161"/>
Community Name (Read Only)	<input type="text" value="public"/>
Community Name (Read Write)	<input type="text" value="private"/>
Trap Destination	
- Port	<input type="text" value="162"/>
- IP Address	<input type="text"/>
- Community Name	<input type="text" value="public"/>
SNMPv3 Settings	
- Status	<input type="radio"/> Enable <input checked="" type="radio"/> Disable
- Username	<input type="text" value="admin"/> (1-31 Characters)
- Authorized Protocol	<input type="text" value="MD5"/>
- Authorized Key	<input type="text" value="12345678"/> (8-32 Characters)
- Private Protocol	<input type="text" value="DES"/>
- Private Key	<input type="text" value="12345678"/> (8-32 Characters)
- Engine ID	<input type="text"/>

CLI Settings

- **Status** – Select **Enable** to enable **Telnet Command Line Interface**. *Default: Disabled*

SSH Settings

- **Status** – Select **Enable** to enable **Secure Shell Interface**. *Default: Disabled*

CLI Setting

Status	<input type="radio"/> Enable <input checked="" type="radio"/> Disable
--------	---

SSH Setting

Status	<input type="radio"/> Enable <input checked="" type="radio"/> Disable
--------	---

Email Alert

- **Status** – Select **Enable** to enable the **Email Alert**
- **From** – Enter the sender of the email alert.
- **To** – Enter the destination receiver email alert.
- **Subject** – Enter the subject to be displayed on the email alert.
- **Email Account**
 - **Username** – Enter the username for the email address.
 - **Password** – Enter the password for the email address.
 - **SMTP Server** – Enter the SMTP Server and its respective port for the email address.
 - **Security Mode** – Select the security mode from the dropdown.
 - **Send Test Mail** – Click this button to send a test email as configured.

Email Alert

Status	<input type="checkbox"/> Enable
- From	<input type="text"/>
- To	<input type="text"/>
- Subject	<input type="text" value="[Email-Alert][TEW-840APBO][3]"/>
Email Account	
- Username	<input type="text"/>
- Password	<input type="password"/> 
- SMTP Server	<input type="text"/> Port: <input type="text" value="25"/>
- Security Mode	<input type="text" value="None"/> <input type="button" value="Send Test Mail"/>

3. Click **Apply** to apply the settings configured.

Time Zone

Management > Time Zone

This page configures the time settings for the access point.

1. Log into your access point management page (see "[Access your access point management page](#)" on page 27).
2. Click on **Time Zone** under **Management** from the left side menu.

Date and Time Settings

- **Manually Set Date and Time** – Check the box to manually set the date and time, then enter in the time below. Or click the **Synchronize with PC** to synchronize the time with your current computer's time.
- **Automatically Get Date and Time** – Check the box to automatically get the date and time from the NTP server filled in the field below.

Date and Time Settings

Manually Set Date and Time

Date: / /

Time: : (24-Hour)

Automatically Get Date and Time

NTP Server:

Time Zone

- **Time Zone** – Select your time zone from the drop down.
- **Enable Daylight Saving** – Check the box to enable automatic daylight savings time adjustment, then adjust the fields accordingly.

Time Zone

Time Zone:

Enable Daylight Saving

Start:

End:

3. Click **Apply** to apply the settings.

WiFi Scheduler

Management > WiFi Scheduler

This page configures the auto reboot and WiFi schedule.

1. Log into your access point management page (see "[Access your access point management page](#)" on page 27).
2. Click on **WiFi Scheduler** under **Management** from the left side menu.

Auto Reboot Setting

- **Status** – Check the box to enable the automatic reboot on the access point.
- **Timer** – Check the box next to the day or days of the week to power cycle the access point. Then set the time in 24:00 format.

Auto Reboot Setting

Status	<input type="radio"/> Enable <input checked="" type="radio"/> Disable
Timer	<input type="checkbox"/> Sunday <input type="checkbox"/> Monday <input type="checkbox"/> Tuesday <input type="checkbox"/> Wednesday <input type="checkbox"/> Thursday <input type="checkbox"/> Friday <input type="checkbox"/> Saturday
	0 : 0

Wi-Fi Scheduler

- **Status** – Check the box to enable the Wi-Fi scheduler. This enables specific date and times when the Wi-Fi radio will be on.
- **Wireless Radio** – Click the drop down to select which wireless radio to schedule.
- **SSID Selection** – Click the drop down and select which SSID to apply the schedule to.
- **Schedule Templates** – Click the drop down and select a template, or choose custom schedule and set the hours on the table below.

Wi-Fi Scheduler

Status	<input checked="" type="radio"/> Enable <input type="radio"/> Disable <small>NOTE: Please assure that the Time Zone Settings is synced with your local time when enabling the Wi-Fi Scheduler</small>
Wireless Radio	5GHz
SSID Selection	TRENDnet840_B4E5
Schedule Templates	Choose a template

3. Click **Save** at the bottom of the page to save your settings.

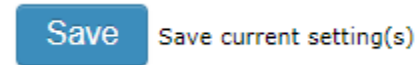

MAKE SURE THE CHANGES TO THE CONFIGURATIONS ARE APPLIED

- Click **Changes** **Changes: 4** from the top right menu bar, and click **Apply**.

OR

- Click **Apply** **Apply** on the bottom right of any page:

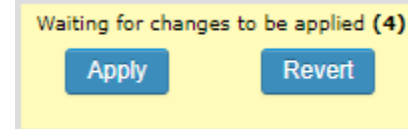

Tools

Management > Tools

This page contains a selection of useful tools.

1. Log into your access point management page (see "[Access your access point management page](#)" on page 27).
2. Click on **Tools** under **Management** from the left side menu.

Ping

- **Target IP / Domain Name** – Enter the IP address or domain name of the ping target.
- **Ping Packet Size** – Specify the ping packet size. Standard ping size is 32 Bytes.
- **Number of Pings** – Specify the number of pings. Standard ping test is 4 pings.
- Press **Start** to begin the test.

Ping Test Parameters

Target IP / Domain Name	<input type="text"/>
Ping Packet Size	<input type="text" value="64"/> Bytes
Number of Pings	<input type="text" value="4"/>
Start	

Traceroute

- **Target IP / Domain Name** – Enter the IP address or domain name of the traceroute target.
- Press **Start** to begin the test.

Traceroute Test Parameters

Target IP / Domain Name	<input type="text" value="www.google.com"/>
Start	
<pre>traceroute to www.google.com (172.217.6.164), 30 hops max, 38 byte packets 1 192.168.10.1 0.625 ms 2 10.83.80.1 11.363 ms</pre>	

Nslookup

- **Target IP / Domain Name** – Enter the IP address or domain name of the name resolution test target.
- Press **Start** to begin the test.

Nslookup Test Parameters

Target IP / Domain Name	<input type="text" value="www.google.com"/>
Start	
<pre>Server: 127.0.0.1 Address 1: 127.0.0.1 localhost Name: www.google.com Address 1: 2607:f8b0:4000:806::2004 dfw28s22-in-x04.1e100.net Address 2: 172.217.6.164 dfw25s17-in-f4.1e100.net</pre>	

Speed Test Parameters

- **Target IP / Domain Name** – Enter the IP address or domain name of the endpoint of the speed test.
- **Time Period** – Specify the duration of the speed test.
- **Check Interval** – Specify the interval between connectivity checks.
- **IPv4 Port** – Enter the IPv4 Port for the destination endpoint of the speed test.
- **IPv6 Port** – Enter the IPv6 Port for the destination endpoint of the speed test.
- Press **Start** to begin the test.

Speed Test Parameters

Target IP / Domain Name	<input type="text"/>
Time Period	<input type="text" value="20"/> Sec
Check Interval	<input type="text" value="5"/> Sec
IPv4 Port	<input type="text" value="5201"/>
IPv6 Port	<input type="text" value="60001"/>
Start	

LED

- **Power** – Select **Enable** to turn **on** the LED. *Default: Enable*
- **Other** – Select **Enable** to turn **on** the remaining LED's. *Default: Enable*

LED Control

Power	<input checked="" type="radio"/> Enable <input type="radio"/> Disable
Other	<input checked="" type="radio"/> Enable <input type="radio"/> Disable
<input type="button" value="Apply"/>	Apply saved settings to take effect

Device Discovery

- **Scan** – Click **Scan** to commence a device discovery. The device details will populate after the scan.

Device Discovery

Device Name	Operation Mode	IP Address	System MAC Address	Firmware Version
TEW-840APBO	AP/WDS BR	192.168.10.51	3C:8C:F8:FD:00:0A	1.0.0

System Manager

Account

System Manager > Account

This section allows configurations of the account passwords.



IMPORTANT NOTE: This device does not have a hardware reset button. When changing the administrator password to the access point configuration page, please make sure to write down your new password.

1. Log into your access point management page (see "[Access your access point management page](#)" on page 27).
2. Click on **Account** under **System Manager** from the left side menu.

Account

- **Administrator Username** – Enter the administrator username if you would like to change it.
- **Current Password** – Enter your current password to apply edits to this page.
- **New Password** – Enter the new password you would like to change to.
- **Verify Password** – Enter the same password you in the previous step.

Account Settings

Administrator Username	<input type="text" value="admin"/>
Current Password	<input type="password"/> 
New Password	<input type="password"/> 
Verify Password	<input type="password"/> 

Apply

3. Click **Apply** to apply the changes on this page.

Firmware

System Manager > Firmware

TRENDnet may periodically release firmware upgrades that may add features or fix problems associated with your TRENDnet device and date/version. To check if there is a firmware upgrade available for your device, please check your TRENDnet model and version using the link. <http://www.trendnet.com/downloads/>

In addition, it is also important to verify if the latest firmware version is newer than the one your AP is currently running. To identify the firmware that is currently loaded on your AP, log in to the AP, click on Overview > Device Status. The firmware version and date used by the AP will be displayed. If there is a newer version available, also review the release notes to check if there were any new features you may want or if any problems were fixed that you may have been experiencing.

1. If a firmware upgrade is available, download the firmware to your computer.
2. Unzip the file to a folder on your computer.

Please note the following:

- Do not interrupt the firmware upgrade process. Do not turn off the device or press the Reset button during the upgrade.
- If you are upgrade the firmware using a laptop computer, ensure that the laptop is connected to a power source or ensure that the battery is fully charged.
- Disable sleep mode on your computer as this may interrupt the firmware upgrade process.
- Do not upgrade the firmware using a wireless connection, only using a wired network connection.
- Any interruptions during the firmware upgrade process may permanently damage your router.

This section allows configurations of the device firmware and backup configurations.

3. Log into your access point management page (see "[Access your access point management page](#)" on page 27).
4. Click on **Firmware** under **System Manager** from the left side menu.

Firmware Upgrade

- **Current Firmware Version** – Displays the current firmware applied to the device.
- **Choose File** – Click this button to browse your local computer for the firmware file.
- **Upload** – Click this button to begin uploading the chosen firmware to the device.

Firmware Upgrade

Current Firmware Version: 1.0.0.9

Select the new firmware from your hard disk.

Choose File No file chosen Upload

Flash Firmware – Verify

- Following uploading the firmware, you will be prompted to verify and proceed with the firmware upgrade. Click **Proceed** to begin the firmware upgrade procedure.

Flash Firmware - Verify

The flash image was uploaded. Below is the checksum and file size listed, compare them with the original file to ensure data integrity. Click "Proceed" below to start the flash procedure.

- Checksum: b987d5a8529c726d75078ab20b17785d
- Size: 11.81 MB

Cancel Proceed

Backup/Restore Settings

Note: User Default replaces factory default whenever resets are applied through the GUI. To reset to factory default after User Default has been set, must select reset to FACTORY DEFAULT settings, or use the physical Reset button located on the device itself or the included PoE Injector.

- **Factory Setting**
 - **Backup Setting** – Click **Export** to export the **CURRENT** configurations as a file downloaded to your computer.
 - **Restore New Setting** – Click **Choose File** to browse your computer for a configuration file to apply to the device. Click **Import** to import the chosen **configuration** file.
 - **Reset to Default** – Click **Reset** to reset the device to **Factory Default**
- **User Setting**
 - **Back Up Setting as Default** – Click **Backup** to set the current configuration as the **User Default**.
 - **Restore to User Default** – Click **Restore** to restore the configuration to the **User Defined Default**.

Backup/Restore Settings

Factory Setting

- Backup Setting Export

- Restore New Setting Choose File No file chosen Import

- Reset to Default Reset

User Setting

- Back Up Setting as Default Backup

- Restore to User Default Restore

- **Warning:** This feature will overwrite the factory default setting with your current AP settings. Pressing the physical reset button or reset on GUI will restore to factory settings.

A similar menu can be found by clicking **Reset** at top right of all GUI screen.

Reboot the device

Caution: Pressing this button will cause the device to reboot.

Reboot the device

Restore the device to default settings

Caution: All settings will be cleared and reset to either factory default or user default.

Restore to Factory Default Restore to User Default

System Log

System Manager > Log

This section contains the system logs for troubleshooting.

1. Log into your access point management page (see "[Access your access point management page](#)" on page 27).
2. Click on **Log** under **System Manager** from the left side menu.

System Log

- **Status** – Click **Enable** to enable to system log.
- **Traffic Log** – Click **Enable** to enable the traffic log.
- **Log Type** – Click the dropdown and select the type of logs to display.
- **Refresh** – Click **Refresh** to refresh the logs.
- **Clear** – Click **Clear** to clear the logs.
- **Remote Log** – Click **Enable** to output the logs to a remote server.
- **Log Server IP Address** – Enter the IP Address for the remote log server.
- **Log Server Port** – Enter the port number for the remote log server.

System Log

Status	<input checked="" type="radio"/> Enable <input type="radio"/> Disable
Traffic Log	<input type="radio"/> Enable <input checked="" type="radio"/> Disable
Log type	ALL <input type="button" value="v"/>
<input type="button" value="Refresh"/>	<pre>Sep 14 02:15:01 TEW-841APBO cron.info crond[3490]: crond: USER root pid 28988 cmd sh /sbin/checkOu Sep 14 02:15:01 TEW-841APBO cron.info crond[3490]: crond: USER root pid 28987 cmd killall -SIGUSR1 c Sep 14 02:14:01 TEW-841APBO cron.info crond[3490]: crond: USER root pid 28471 cmd sh /sbin/checkOu Sep 14 02:14:01 TEW-841APBO cron.info crond[3490]: crond: USER root pid 28470 cmd killall -SIGUSR1 c Sep 14 02:13:01 TEW-841APBO cron.info crond[3490]: crond: USER root pid 27834 cmd sh /sbin/checkOu Sep 14 02:13:01 TEW-841APBO cron.info crond[3490]: crond: USER root pid 27833 cmd killall -SIGUSR1 c Sep 14 02:12:01 TEW-841APBO cron.info crond[3490]: crond: USER root pid 25920 cmd sh /sbin/checkOu Sep 14 02:12:01 TEW-841APBO cron.info crond[3490]: crond: USER root pid 25919 cmd killall -SIGUSR1 c Sep 14 02:11:01 TEW-841APBO cron.info crond[3490]: crond: USER root pid 25351 cmd sh /sbin/checkOu Sep 14 02:11:01 TEW-841APBO cron.info crond[3490]: crond: USER root pid 25350 cmd killall -SIGUSR1 c</pre>
<input type="button" value="Clear"/>	
Remote Log	<input type="radio"/> Enable <input checked="" type="radio"/> Disable
Log Server IP Address	<input type="text" value="0.0.0.0"/>
Log Server Port	<input type="text" value="514"/>
<input type="button" value="Apply"/>	Apply saved settings to take effect

3. Click on **Apply** to apply the log settings.

System Log

To log out of the access point, click logout from the top right menu from any screen, then click **OK** on the pop-up dialog box.

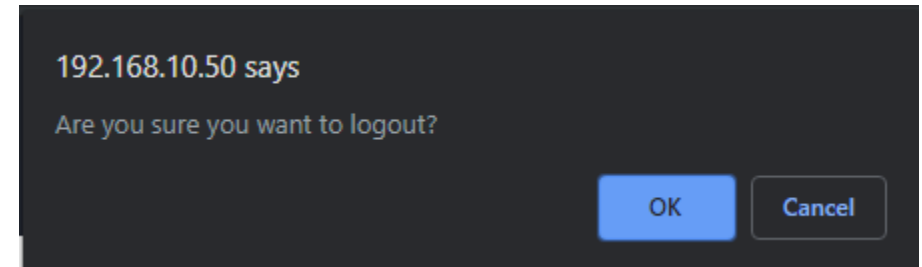

Technical Specifications

Standards

- IEEE 802.3
- IEEE 802.3u
- IEEE 802.3x
- IEEE 802.3ab
- IEEE 802.3az
- IEEE 802.3at
- IEEE 802.1Q
- IEEE 802.11a
- IEEE 802.11b
- IEEE 802.11g
- IEEE 802.11n (up to 400Mbps @ 256QAM)
- IEEE 802.11ac Wave 2 (5GHz: up to 867Mbps @ 256QAM)

Hardware Interface

- 1 x PoE+ Gigabit LAN port (power input)
- 4 x RP-SMA (female) antenna connectors
- LED indicators

Features

- 802.11ac MU-MIMO Wave 2 support
- IP67 rated housing
- Concurrent dual band
- Band steering
- WiFi traffic shaping
- 802.1Q VLAN assignment per SSID
- IPv6 support (Link-Local, Static IPv6)
- LEDs on/off
- 802.11k intelligent radio resource management
- RSSI Threshold (client signal strength and connectivity control)

Operation Modes

- Access Point
- Client Bridge
- WDS Access Point
- WDS Bridge
- WDS Station

Management/Monitoring

- Web based management
- SNMP v1/v2c/v3
- STP
- Event logging
- Ping test
- Traceroute
- Nslookup
- Telnet

Access Control

- Wireless encryption: WEP, WPA/WPA2-PSK, WPA/WPA2-RADIUS
- MAC filter
- Maximum client limit

QoS

- WMM
- Bandwidth control per SSID or client

SSID

- Up to 8 SSIDs

Frequency

- 2.4GHz: 2.412 – 2.462GHz
- 5GHz: 5.180 – 5.240GHz, 5.745 – 5.825GHz

Wireless Channels

- 2.4GHz: FCC: 1–11
- 5GHz: FCC: 36, 40, 44, 48, 149, 153, 157, 161 and 165

Modulation

- DBPSK/DQPSK/CCK for DSSS technique
- BPSK/QPSK/16-QAM/64-QAM/256-QAM for OFDM technique

Antenna Gain

- 2.4GHz: 2 x 5 dBi external
- 5GHz: 2 x 5 dBi external

Wireless Output Power

- 802.11a: FCC/IC: 19 dBm (max.)
- 802.11b: FCC/IC: 19 dBm (max.)
- 802.11g: FCC/IC: 19 dBm (max.)
- 802.11n (2.4GHz): FCC/IC: 19 dBm (max.)
- 802.11n (5GHz): FCC/IC: 19 dBm (max.)
- 802.11ac: FCC/IC: 19 dBm (max.)

Receiving Sensitivity

- 802.11a: -72 dBm (typical) @ 54 Mbps
- 802.11b: -87 dBm (typical) @ 11 Mbps
- 802.11g: -72 dBm (typical) @ 54 Mbps
- 802.11n (2.4 GHz): -67 dBm (typical) @ 400 Mbps
- 802.11n (5 GHz): -61 dBm (typical) @ 400 Mbps
- 802.11ac: -58 dBm (typical) @ 867 Mbps

Power

- IEEE 802.3at Type 2 PoE PD Class 4
- Max. consumption: 12.6W

Operating Temperature

- -22° – 60° C (-7.6° – 140° F)

Operating Humidity

- Max. 90% non-condensing

Certifications

- FCC
- IC

Dimensions

- 111 x 174 x 38mm (4.4 x 6.9 x 1.5 in.)

Weight

- 302g (10.7 oz.)

Warranty:

- 3 year

Package Contents

- TEW-841APBO
- 2 x Detachable 2.4GHz 5 dBi antennas
- 2 x Detachable 5GHz 5 dBi antennas
- IP67 weather rated cable gland
- Mounting hardware
- Quick Installation Guide

Disclaimer

*Maximum wireless signal rates are referenced from IEEE 802.11 theoretical specifications. Actual data throughput and coverage will vary depending on interference, network traffic, building materials and other conditions. For maximum performance of up to 867Mbps use with an 867Mbps 802.11ac wireless adapter. For maximum performance of up to 400Mbps, use with a 400Mbps 802.11n wireless adapter. Multi-User MIMO (MU-MIMO) requires the use of multiple MU-MIMO enabled wireless adapters.

Appendix

How to find your IP address?

Note: Please note that although the following procedures provided to follow for your operating system on configuring your network settings can be used as general guidelines, however, it is strongly recommended that you consult your computer or operating system manufacturer directly for assistance on the proper procedure for configuring network settings.

Command Prompt Method

Windows 2000/XP/Vista/7/8.1/10

1. On your keyboard, press **Windows Logo+R** keys simultaneously to bring up the Run dialog box.
2. In the dialog box, type **cmd** to bring up the command prompt.
3. In the command prompt, type **ipconfig /all** to display your IP address settings.

MAC OS X

1. Navigate to your **Applications** folder and open **Utilities**.
2. Double-click on **Terminal** to launch the command prompt.
3. In the command prompt, type **ipconfig getifaddr <en0 or en1>** to display the wired or wireless IP address settings.

Note: **en0** is typically the wired Ethernet and **en1** is typically the wireless Airport interface.

Graphical Method

MAC OS 10.6/10.5

1. From the Apple menu, select **System Preferences**.
2. In System Preferences, from the **View** menu, select **Network**.
3. In the Network preference window, click a network port (e.g., Ethernet, AirPort, modem). If you are connected, you'll see your IP address settings under "Status:"

MAC OS 10.4

1. From the Apple menu, select **Location**, and then **Network Preferences**.
2. In the Network Preference window, next to "Show:", select **Network Status**. You'll see your network status and your IP address settings displayed.

Note: If you are experiencing difficulties, please contact your computer or operating system manufacturer for assistance.

How to configure your network settings to obtain an IP address automatically or use DHCP?

Note: Please note that although the following procedures provided to follow for your operating system on configuring your network settings can be used as general guidelines, however, it is strongly recommended that you consult your computer or operating system manufacturer directly for assistance on the proper procedure for configuring network settings.

Windows 7/8.1/10

- a. Go into the **Control Panel**, click **Network and Sharing Center**.
- b. Click **Change Adapter Settings**, right-click the **Local Area Connection** icon.
- c. Then click **Properties** and click **Internet Protocol Version 4 (TCP/IPv4)**.
- d. Then click **Obtain an IP address automatically** and click **OK**.

Windows Vista

- a. Go into the **Control Panel**, click **Network and Internet**.
- b. Click **Manage Network Connections**, right-click the **Local Area Connection** icon and click **Properties**.
- c. Click **Internet Protocol Version (TCP/IPv4)** and then click **Properties**.
- d. Then click **Obtain an IP address automatically** and click **OK**.

Windows XP/2000

- a. Go into the **Control Panel**, double-click the **Network Connections** icon
- b. Right-click the **Local Area Connection** icon and the click **Properties**.
- c. Click **Internet Protocol (TCP/IP)** and click **Properties**.
- d. Then click **Obtain an IP address automatically** and click **OK**.

MAC OS 10.4/10.5/10.6

- a. From the **Apple**, drop-down list, select **System Preferences**.
- b. Click the **Network** icon.
- c. From the **Location** drop-down list, select **Automatic**.
- d. Select and view your Ethernet connection.
 - In MAC OS 10.4, from the **Show** drop-down list, select **Built-in Ethernet** and select the **TCP/IP** tab.
 - In MAC OS 10.5/10.6, in the left column, select **Ethernet**.
- e. Configure TCP/IP to use DHCP.

In MAC 10.4, from the **Configure IPv4**, drop-down list, select **Using DHCP** and click the **Apply Now** button.

In MAC 10.5, from the **Configure** drop-down list, select **Using DHCP** and click the **Apply** button.

In MAC 10.6, from the **Configure** drop-down list, select **Using DHCP** and click the **Apply** button.

f. Restart your computer.

Note: *If you are experiencing difficulties, please contact your computer or operating system manufacturer for assistance.*

How to configure your network settings to use a static IP address?

Note: *Please note that although the following procedures provided to follow for your operating system on configuring your network settings can be used as general guidelines, however, it is strongly recommended that you consult your computer or operating system manufacturer directly for assistance on the proper procedure for configuring network settings.*

Windows 7/8.1/10

- a. Go into the **Control Panel**, click **Network and Sharing Center**.
- b. Click **Change Adapter Settings**, right-click the **Local Area Connection** icon.
- c. Then click **Properties** and click **Internet Protocol Version 4 (TCP/IPv4)**.
- d. Then click **Use the following IP address**, and assign your network adapter a static IP address. Click **OK**

Windows Vista

- a. Go into the **Control Panel**, click **Network and Internet**.
- b. Click **Manage Network Connections**, right-click the **Local Area Connection** icon and click **Properties**.
- c. Click **Internet Protocol Version (TCP/IPv4)** and then click **Properties**.
- d. Then click **Use the following IP address**, and assign your network adapter a static IP address. Click **OK**

Windows XP/2000

- a. Go into the **Control Panel**, double-click the **Network Connections** icon
- b. Right-click the **Local Area Connection** icon and the click **Properties**.
- c. Click **Internet Protocol (TCP/IP)** and click **Properties**.

d. Then click **Use the following IP address**, and assign your network adapter a static IP address. Click **OK**

MAC OS 10.4/10.5/10.6

- a. From the **Apple**, drop-down list, select **System Preferences**.
- b. Click the **Network** icon.
- c. From the **Location** drop-down list, select **Automatic**.
- d. Select and view your Ethernet connection.

How to find your MAC address?

In Windows 2000/XP/Vista/7/8,

Your computer MAC addresses are also displayed in this window, however, you can type **getmac -v** to display the MAC addresses only.

In MAC OS 10.4,

1. **Apple Menu > System Preferences > Network**
2. From the **Show** menu, select **Built-in Ethernet**.
3. On the **Ethernet** tab, the **Ethernet ID** is your MAC Address.

In MAC OS 10.5/10.6,

1. **Apple Menu > System Preferences > Network**
2. Select **Ethernet** from the list on the left.
3. Click the **Advanced** button.
3. On the **Ethernet** tab, the **Ethernet ID** is your MAC Address.

How do I use the ping tool to check for network device connectivity?**Windows 2000/XP/Vista/7/8.1/10**

1. On your keyboard, press **Windows Logo+R** keys simultaneously to bring up the Run dialog box.
2. In the dialog box, type **cmd** to bring up the command prompt.
3. In the command prompt, type **ping <ip_address>** with the *<ip_address>* being the IP address you want ping and check for connectivity.

Example: Usage of ping command and successful replies from device.

```
C:\Users>ping 192.168.10.100
```

```
Pinging 192.168.10.100 with 32 bytes of data:
```

```
Reply from 192.168.10.100: bytes=32 time<1ms TTL=64
```

```
Reply from 192.168.10.100: bytes=32 time<1ms TTL=64
```

```
Reply from 192.168.10.100: bytes=32 time<1ms TTL=64
```

```
Reply from 192.168.10.100: bytes=32 time<1ms TTL=64
```

Ping statistics for 192.168.10.100:

```
Packets: Sent = 4, Received = 4, Lost = 0 (0% loss),
```

Approximate round trip times in milli-seconds:

```
Minimum = 0ms, Maximum = 0ms, Average = 0ms
```

MAC OS X



1. Navigate to your **Applications** folder and open **Utilities**.
2. Double-click on **Terminal** to launch the command prompt.
3. In the command prompt, type **ping -c <#> <ip_address>** with the *<#>* ping being the number of time you want to ping and the *<ip_address>* being the IP address you want ping and check for connectivity.

Example: `ping -c 4 192.168.10.100`

How to connect to a wireless network using the built-in Windows utility?

Note: Please note that although the following procedures provided to follow for your operating system on configuring your network settings can be used as general guidelines, however, it is strongly recommended that you consult your computer or operating system manufacturer directly for assistance on the proper procedure for connecting to a wireless network using the built-in utility.

Windows 7/8.1/10

1. Open Connect to a Network by clicking the network icon ( or ) in the notification area.
2. In the list of available wireless networks, click the wireless network you would like to connect to, then click **Connect**.
4. You may be prompted to enter a security key in order to connect to the network.
5. Enter in the security key corresponding to the wireless network, and click **OK**.

Windows Vista

1. Open Connect to a Network by clicking the **Start Button**  and then click **Connect To**.
2. In the **Show** list, click **Wireless**.
3. In the list of available wireless networks, click the wireless network you would like to connect to, then click **Connect**.
4. You may be prompted to enter a security key in order to connect to the network.
5. Enter in the security key corresponding to the wireless network, and click **OK**.

Windows XP

1. Right-click the network icon in the notification area, then click **View Available Wireless Networks**.
2. In **Connect to a Network**, under **Available Networks**, click the wireless network you would like to connect to.
3. You may be prompted to enter a security key in order to connect to the network.
4. Enter in the security key corresponding to the wireless network, and click **Connect**.

Federal Communication Commission Interference Statement

This device complies with Part 15 of the FCC Rules. Operation is subject to the following two conditions: (1) This device may not cause harmful interference, and (2) this device must accept any interference received, including interference that may cause undesired operation.

This equipment has been tested and found to comply with the limits for a Class B digital device, pursuant to Part 15 of the FCC Rules. These limits are designed to provide reasonable protection against harmful interference in a residential installation. This equipment generates, uses and can radiate radio frequency energy and, if not installed and used in accordance with the instructions, may cause harmful interference to radio communications. However, there is no guarantee that interference will not occur in a particular installation. If this equipment does cause harmful interference to radio or television reception, which can be determined by turning the equipment off and on, the user is encouraged to try to correct the interference by one of the following measures:

- Reorient or relocate the receiving antenna.
- Increase the separation between the equipment and receiver.
- Connect the equipment into an outlet on a circuit different from that to which the receiver is connected.
- Consult the dealer or an experienced radio/TV technician for help.

FCC Caution: Any changes or modifications not expressly approved by the party responsible for compliance could void the user's authority to operate this equipment.

This transmitter must not be co-located or operating in conjunction with any other antenna or transmitter.



Radiation Exposure Statement:

This equipment complies with FCC radiation exposure limits set forth for an uncontrolled environment. This equipment should be installed and operated with minimum distance 20cm between the radiator & your body. one of the following measures:

Industry Canada Statement

This device complies with ISED's licence-exempt RSSs. Operation is subject to the following two conditions: (1) This device may not cause harmful interference, and (2) this device must accept any interference received, including interference that may cause undesired operation.

Le présent appareil est conforme aux CNR d'ISED applicables aux appareils radio exempts de licence. L'exploitation est autorisée aux deux conditions suivantes : (1) le dispositif ne doit pas produire de brouillage préjudiciable, et (2) ce dispositif doit accepter tout brouillage reçu, y compris un brouillage susceptible de provoquer un fonctionnement indésirable.

Caution :

- (i) the device for operation in the band 5150-5250 MHz is only for indoor use to reduce the potential for harmful interference to co-channel mobile satellite systems;
- (ii) for devices with detachable antenna(s), the maximum antenna gain permitted for devices in the band 5725-5850 MHz shall be such that the equipment still complies with the e.i.r.p. limits as appropriate;
- (iii) where applicable, antenna type(s), antenna models(s), and worst-case tilt angle(s) necessary to remain compliant with the e.i.r.p. elevation mask requirement set forth in section 6.2.2.3 shall be clearly indicated.

Avertissement:

- (i) les dispositifs fonctionnant dans la bande 5150-5250 MHz sont réservés uniquement pour une utilisation à l'intérieur afin de réduire les risques de brouillage préjudiciable aux systèmes de satellites mobiles utilisant les mêmes canaux;
- (ii) pour les dispositifs munis d'antennes amovibles, le gain maximal d'antenne permis (pour les dispositifs utilisant la bande de 5 725 à 5 850 MHz) doit être conforme à la limite de la p.i.r.e. spécifiée, selon le cas;

(iii) lorsqu'il y a lieu, les types d'antennes (s'il y en a plusieurs), les numéros de modèle de l'antenne et les pires angles d'inclinaison nécessaires pour rester conforme à l'exigence de la p.i.r.e. applicable au masque d'élévation, énoncée à la section 6.2.2.3, doivent être clairement indiqués.

Radiation Exposure Statement:

This equipment complies with ISED radiation exposure limits set forth for an uncontrolled environment. This equipment should be installed and operated with greater than 20cm between the radiator & your body.

Déclaration d'exposition aux radiations:

Cet équipement est conforme aux limites d'exposition aux rayonnements ISED établies pour un environnement non contrôlé. Cet équipement doit être installé et utilisé à plus de 20cm entre le radiateur et votre corps.

Approved antenna list

Type	Gain	Brand	Manufacturer
External Omni-Directional	5dBi	MASTER WAVE	MASTER WAVE
External Omni-Directional	5dBi	MASTER WAVE	MASTER WAVE

Professional installation instruction

1. Installation personal

This product is designed for specific application and needs to be installed by a qualified personal who has RF and related rule knowledge. The general user shall not attempt to install or change the setting.

2. Installation location

The product shall be installed at a location where the radiating antenna can be kept 20cm from nearby person in normal operation condition to meet regulatory RF exposure requirement.

3. External antenna

Use only the antennas which have been approved by the applicant. The non-approved antenna(s) may produce unwanted spurious or excessive RF transmitting power which may lead to the violation of FCC/IC limit and is prohibited.

4. Installation procedure

Please refer to user's manual for the detail.

5. Warning

Please carefully select the installation position and make sure that the final output power does not exceed the limit set force in relevant rules. The violation of the rule could lead to serious federal penalty.

Limited Warranty

TRENDnet warrants only to the original purchaser of this product from a TRENDnet authorized reseller or distributor that this product will be free from defects in material and workmanship under normal use and service. This limited warranty is non-transferable and does not apply to any purchaser who bought the product from a reseller or distributor not authorized by TRENDnet, including but not limited to purchases from Internet auction sites.

Limited Warranty

TRENDnet warrants its products against defects in material and workmanship, under normal use and service. Specific warranty periods are listed on each of the respective product pages on the TRENDnet website.

- AC/DC Power Adapter, Cooling Fan, and Power Supply carry a one-year warranty.

Limited Lifetime Warranty

TRENDnet offers a limited lifetime warranty for all of its metal-enclosed network switches that have been purchased in the United States/Canada on or after 1/1/2015.

- Cooling fan and internal power supply carry a one-year warranty

To obtain an RMA, the ORIGINAL PURCHASER must show Proof of Purchase and return the unit to the address provided. The customer is responsible for any shipping-related costs that may occur. Replacement goods will be shipped back to the customer at TRENDnet's expense.

Upon receiving the RMA unit, TRENDnet may repair the unit using refurbished parts. In the event that the RMA unit needs to be replaced, TRENDnet may replace it with a refurbished product of the same or comparable model.

In the event that, after evaluation, TRENDnet cannot replace the defective product or there is no comparable model available, we will refund the depreciated value of the product.

If a product does not operate as warranted during the applicable warranty period, TRENDnet shall reserve the right, at its expense, to repair or replace the defective product or part and deliver an equivalent product or part to the customer. The repair/replacement unit's warranty continues from the original date of purchase. All products that are replaced become the property of TRENDnet. Replacement products may be new or reconditioned. TRENDnet does not issue refunds or credit. Please contact the point-of-purchase for their return policies.

TRENDnet shall not be responsible for any software, firmware, information, or memory data of customer contained in, stored on, or integrated with any products returned to TRENDnet pursuant to any warranty.

There are no user serviceable parts inside the product. Do not remove or attempt to service the product by any unauthorized service center. This warranty is voided if (i) the product has been modified or repaired by any unauthorized service center, (ii) the product was subject to accident, abuse, or improper use, or (iii) the product was subject to conditions more severe than those specified in the manual.

Warranty service may be obtained by contacting TRENDnet within the applicable warranty period and providing a copy of the dated proof of the purchase. Upon proper submission of required documentation, a Return Material Authorization (RMA) number will be issued. An RMA number is required in order to initiate warranty service support for all TRENDnet products. Products that are sent to TRENDnet for RMA service must have the RMA number marked on the outside of return packages and sent to TRENDnet prepaid, insured and packaged appropriately for safe shipment. International customers

shipping from outside of the USA and Canada are responsible for any return shipping and/or customs charges, including but not limited to, duty, tax, and other fees.

Refurbished product: Refurbished products carry a 90-day warranty after date of purchase. Please retain the dated sales receipt with purchase price clearly visible as evidence of the original purchaser's date of purchase. Replacement products may be refurbished or contain refurbished materials. If TRENDnet, by its sole determination, is unable to replace the defective product, we will offer a refund for the depreciated value of the product.

WARRANTIES EXCLUSIVE: IF THE TRENDNET PRODUCT DOES NOT OPERATE AS WARRANTED ABOVE, THE CUSTOMER'S SOLE REMEDY SHALL BE, AT TRENDNET'S OPTION, REPAIR OR REPLACE. THE FOREGOING WARRANTIES AND REMEDIES ARE EXCLUSIVE AND ARE IN LIEU OF ALL OTHER WARRANTIES, EXPRESSED OR IMPLIED, EITHER IN FACT OR BY OPERATION OF LAW, STATUTORY OR OTHERWISE, INCLUDING WARRANTIES OF MERCHANTABILITY AND FITNESS FOR A PARTICULAR PURPOSE. TRENDNET NEITHER ASSUMES NOR AUTHORIZES ANY OTHER PERSON TO ASSUME FOR IT ANY OTHER LIABILITY IN CONNECTION WITH THE SALE, INSTALLATION, MAINTENANCE, OR USE OF TRENDNET'S PRODUCTS.

TRENDNET SHALL NOT BE LIABLE UNDER THIS WARRANTY IF ITS TESTING AND EXAMINATION DISCLOSE THAT THE ALLEGED DEFECT IN THE PRODUCT DOES NOT EXIST OR WAS CAUSED BY CUSTOMER'S OR ANY THIRD PERSON'S MISUSE, NEGLIGENCE, IMPROPER INSTALLATION OR TESTING, UNAUTHORIZED ATTEMPTS TO REPAIR OR MODIFY, OR ANY OTHER CAUSE BEYOND THE RANGE OF THE INTENDED USE, OR BY ACCIDENT, FIRE, LIGHTNING, OR OTHER HAZARD.

LIMITATION OF LIABILITY: TO THE FULL EXTENT ALLOWED BY LAW, TRENDNET ALSO EXCLUDES FOR ITSELF AND ITS SUPPLIERS ANY LIABILITY, WHETHER BASED IN

CONTRACT OR TORT (INCLUDING NEGLIGENCE), FOR INCIDENTAL, CONSEQUENTIAL, INDIRECT, SPECIAL, OR PUNITIVE DAMAGES OF ANY KIND, OR FOR LOSS OF REVENUE OR PROFITS, LOSS OF BUSINESS, LOSS OF INFORMATION OR DATE, OR OTHER FINANCIAL LOSS ARISING OUT OF OR IN CONNECTION WITH THE SALE, INSTALLATION, MAINTENANCE, USE, PERFORMANCE, FAILURE, OR INTERRUPTION OF THE POSSIBILITY OF SUCH DAMAGES, AND LIMITS ITS LIABILITY TO REPAIR, REPLACEMENT, OR REFUND OF THE PURCHASE PRICE PAID, AT TRENDNET'S OPTION. THIS DISCLAIMER OF LIABILITY FOR DAMAGES WILL NOT BE AFFECTED IF ANY REMEDY PROVIDED HEREIN SHALL FAIL OF ITS ESSENTIAL PURPOSE.

Governing Law: This Limited Warranty shall be governed by the laws of the state of California.

Some TRENDnet products include software code written by third party developers. These codes are subject to the GNU General Public License ("GPL") or GNU Lesser General Public License ("LGPL").

Visit <http://www.trendnet.com/gpl> or the support section on <http://www.trendnet.com> and search for the desired TRENDnet product to access to the GPL Code or LGPL Code. These codes are distributed WITHOUT WARRANTY and are subject to the copyrights of the developers. TRENDnet does not provide technical support for these codes. Please visit <http://www.gnu.org/licenses/gpl.txt> or <http://www.gnu.org/licenses/lgpl.txt> for specific terms of each license.

PWP07172015v3

2019/09/16



Product Warranty Registration

Please take a moment to register your product online.
Go to TRENDnet's website at <http://www.trendnet.com/register>

TRENDnet
20675 Manhattan Place
Torrance, CA 90501. USA