

KVM Tutorial

TABLE OF CONTENTS

Introduction to KVM Technology	1
Benefits of KVM Switches	2
Basic Components of KVM Technology	3
TRENDnet KVM Product Line	8
Glossary	13

Introduction on KVM Technology

KVM stands for "keyboard, video, and mouse." A KVM switch is a hardware device that allows you to use a single keyboard, monitor, and mouse to control multiple computers. Any computer connected to the KVM switch can be easily accessed by either pressing a button on the KVM switch or using a keystroke combination on your keyboard ("Hot-Keys").

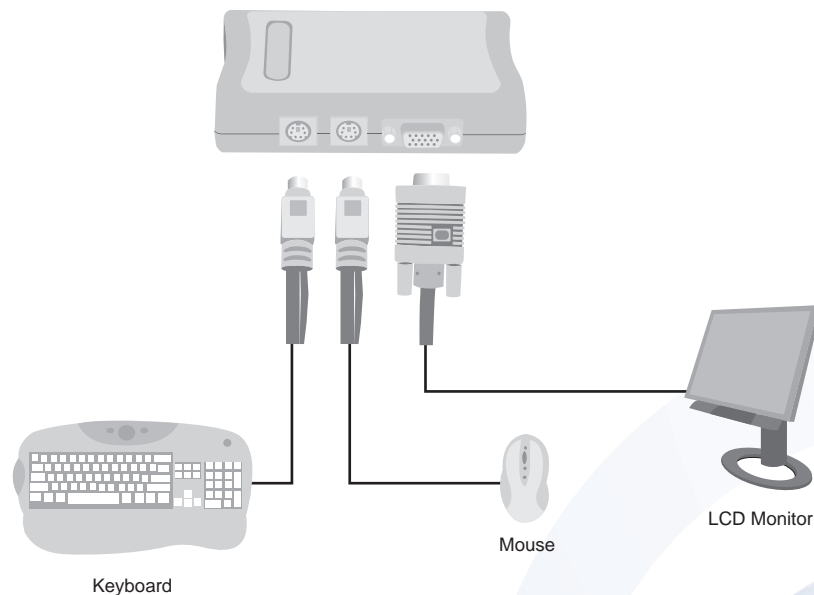

Depending on the number of ports of the selected KVM switch, you can control from 2 to 16 computers. Other enterprise KVM switches allow you to combine or "stack" KVM switches together to control from 128 to 256 computers. There are also audio-rich KVM solutions that offer digital playback and recording, and video-enhanced KVM switches that display crisp, digital images.

An essential function of all KVM switches is to properly emulate a keyboard and mouse so that the operating system functions properly. Good KVM switches use microprocessors to emulate keyboard, mouse, and monitor hardware while mechanical KVM switches cannot emulate peripherals. Some computers will not boot if a keyboard is not found (unless you modify a BIOS setting). For Windows users, if a mouse is not detected during startup, a pointer is never displayed.

Software alternatives such as PC Anywhere imitate KVM switches by allowing you to switch and forward input over network connections. This has the advantage of reducing the number of wires needed to control multiple computers. However, software alternatives use system resources that reduce your computer's overall performance whereas hardware KVM switches have built-in microprocessors that handle switching from one workstation to another.

Benefits of KVM Switches

The benefits of using KVM switches vary from one application to another. Below are some of the common KVM switch applications and benefits:

- **Increased Workspace** - KVM switches are specifically designed to manage several computers with one keyboard, mouse, and monitor. Administrators who manage server farms can greatly reduce the necessity of extra peripherals by centralizing control through the KVM switch.
- **Return on Equipment Investment** - KVM switches allow you to use legacy hardware and software, allowing a greater return on investment from your past computer purchases. When you upgrade your home or office with a brand-new workstation, you can reap the benefits of faster load times and more multi-tasking operations. However, some of the older programs that were compatible with your older computer are not compatible with your new workstation, so you end up sacrificing all your software utilities with extra purchases on new programs. Fortunately, with KVM switches, you can create a cost-effective solution to use your older computer with your new workstation. You can continue using legacy software with your older computer and conveniently switch to your newer workstation for CPU intensive applications. Simply put, you can use all your spread sheet and word processing applications on an older computer, and switch to your newer workstation to play multi-media applications such as streaming video, DVD movies, or high-resolution graphics for gaming.
- **Convenient Access** - KVM switches allow you to connect to several workstations without moving from one location to another. Imagine working in a server room environment where fans are constantly blaring to keep your server and switches cool. The noise from hard drives writing, the LEDs blinking randomly and the tangled mess of wires twirling around switches and patch panels constantly disrupting your concentration on working on company projects. Wouldn't a better environment improve productivity to manage network equipment? That's where KVM switches solve this problem.

Network administrators do not have to go into secure server room locations to work on projects and trouble shooting issues. They can conveniently work in a productive environment and switch to the main server when an error occurs. By using KVM switches to access server room devices, network administrators can continue to work on management projects in a stable environment and access critical devices in the server room when the need becomes necessary.

With the introduction of IP over KVM switches, network administrators can even control PCs from a remote location. Enabled with Internet connectivity, your IT staff has the power to execute troubleshooting and maintenance tasks from any off site location via a standard web browser.

- **Cost-Effective Solution** - KVM switches allow you to reduce the number of redundant peripherals by simplifying the use of several workstations into one keyboard, mouse, and monitor. Each individual workstation does not need its own keyboard, monitor, and mouse. A KVM switch will control all connected workstations, eliminating the purchase of new hardware.

When data centers increase the number of workstations, extra peripherals do not have to be purchased. KVM switches immediately solve scalable growth for data centers.

Using new IP over KVM switches, not only do you save on equipment costs, but also on the need for additional IT man power and hours. With remote management capabilities, network administrators can easily perform maintenance and configuration tasks from home, thus freeing you from employing a local administrator or contracting with a field technician to deal with satellite locations.

KVM Basic Components

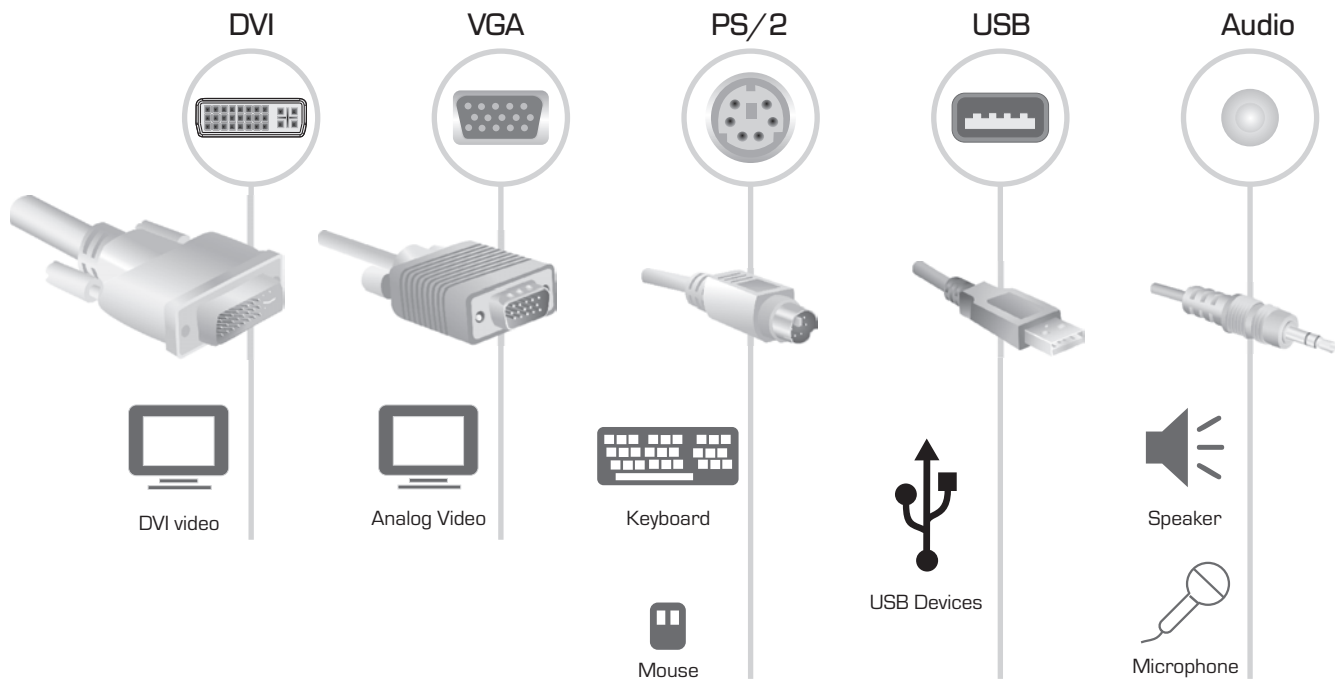

Console Connection Interface is generally located on the front of the KVM switch. Your common Console Interface includes two Personal System/2 (PS/2) ports for keyboard and mouse connectivity, and one Video port for computer monitor connectivity. The Console Interfaces are used to connect the primary keyboard, video and mouse for control over multiple workstations.

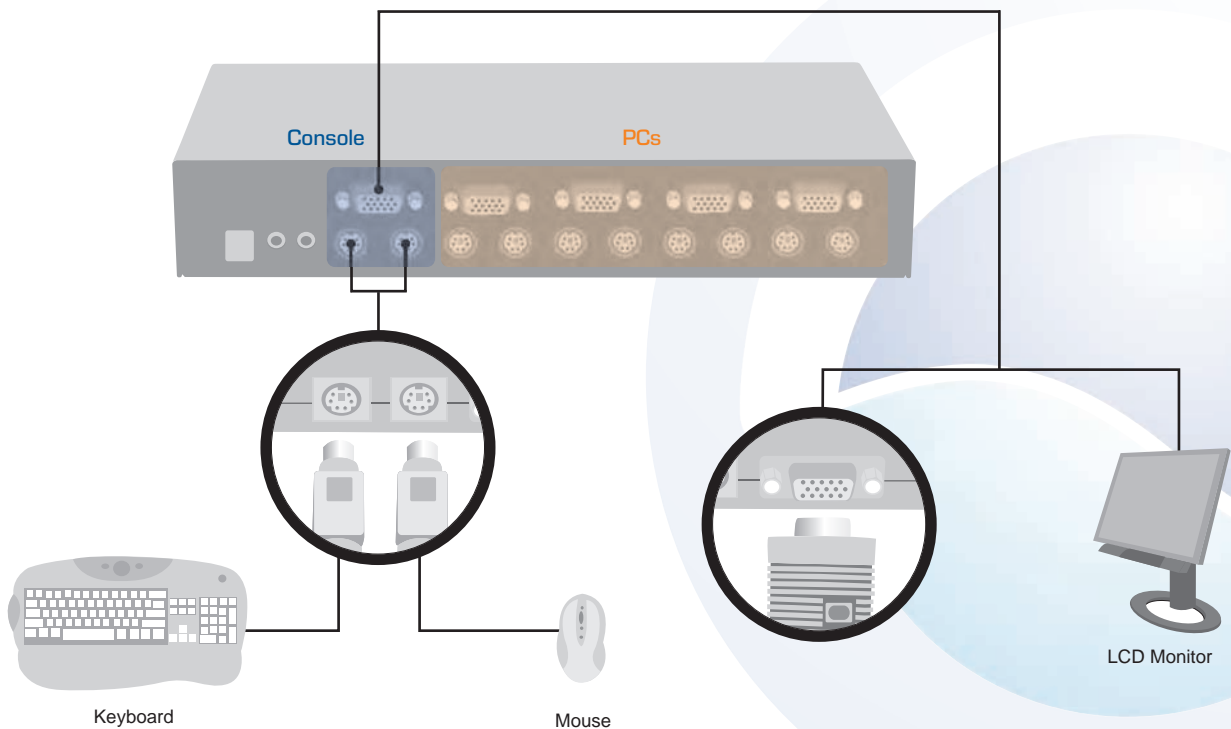

PC Connection Interface usually involves the same type of connectors as the console port, but it's not unusual to find a mix of interfaces (e.g. USB, PS/2, VGA, DVI, and Audio) too. The PC Interface provides connectivity to the KVM switch, and enables the user to switch between multiple computers while only using one keyboard, mouse, and computer monitor. The PC Interface also provides power to the KVM via the PS/2 ports, and therefore no additional power adapter is needed.

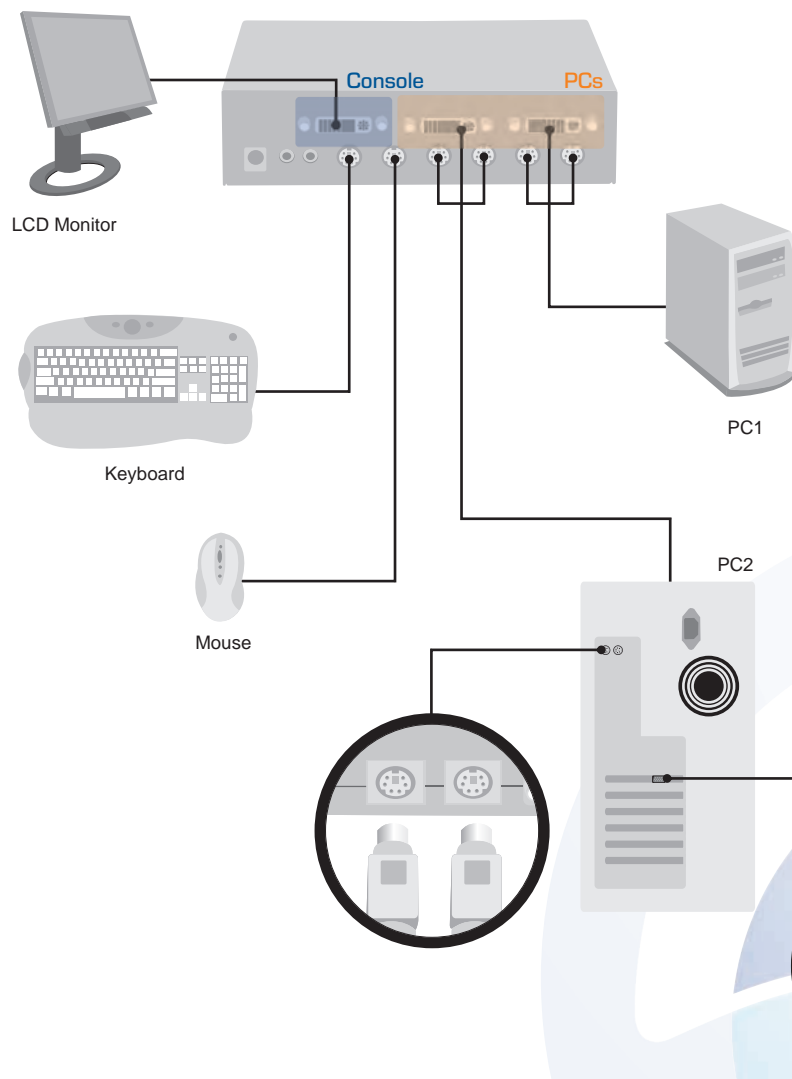

Enhanced Multimedia Support

Audio Support is becoming more evident in KVM switches because of the cost saving solutions it can provide. A KVM with audio provides the interfaces for speakers and/or microphones to reduce costs associated with buying separate audio devices for each computer.

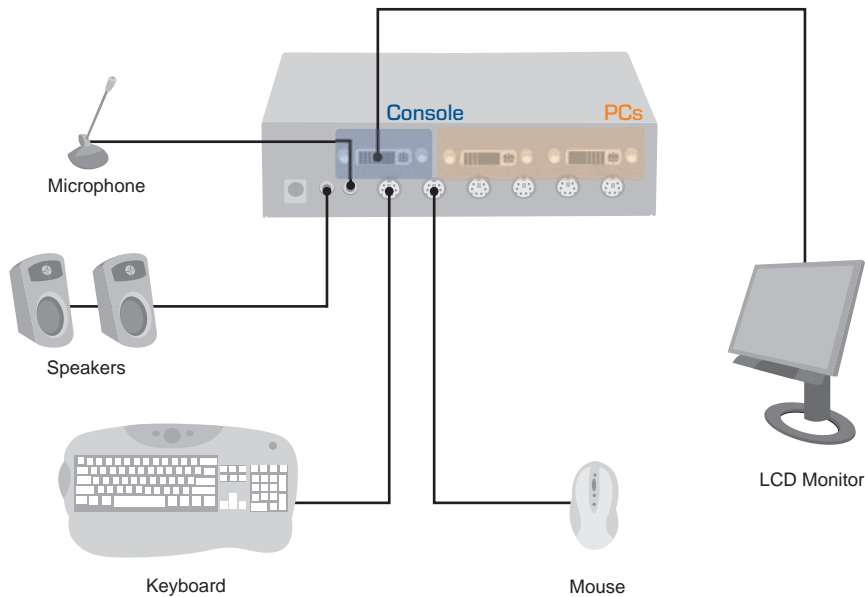

Digital Visual Interface (DVI) is used to create a digital connection from the computer to the monitor. Unlike VGA, DVI provides direct representation of digital signals, creating a clearer more defined display. DVI monitors are generally used for graphic intensive applications such as gaming and graphic design.

Network Connectivity

IP over KVM combines the functionality of controlling multiple computers using a single set of peripherals, with the convenience of remote access via any IP network, including the Internet. Using a standard web browser, this powerful device gives network administrators the ability to view and control everything from BIOS level and CMOS settings during boot up, to application GUIs, and daily maintenance tasks, all from a remote location.

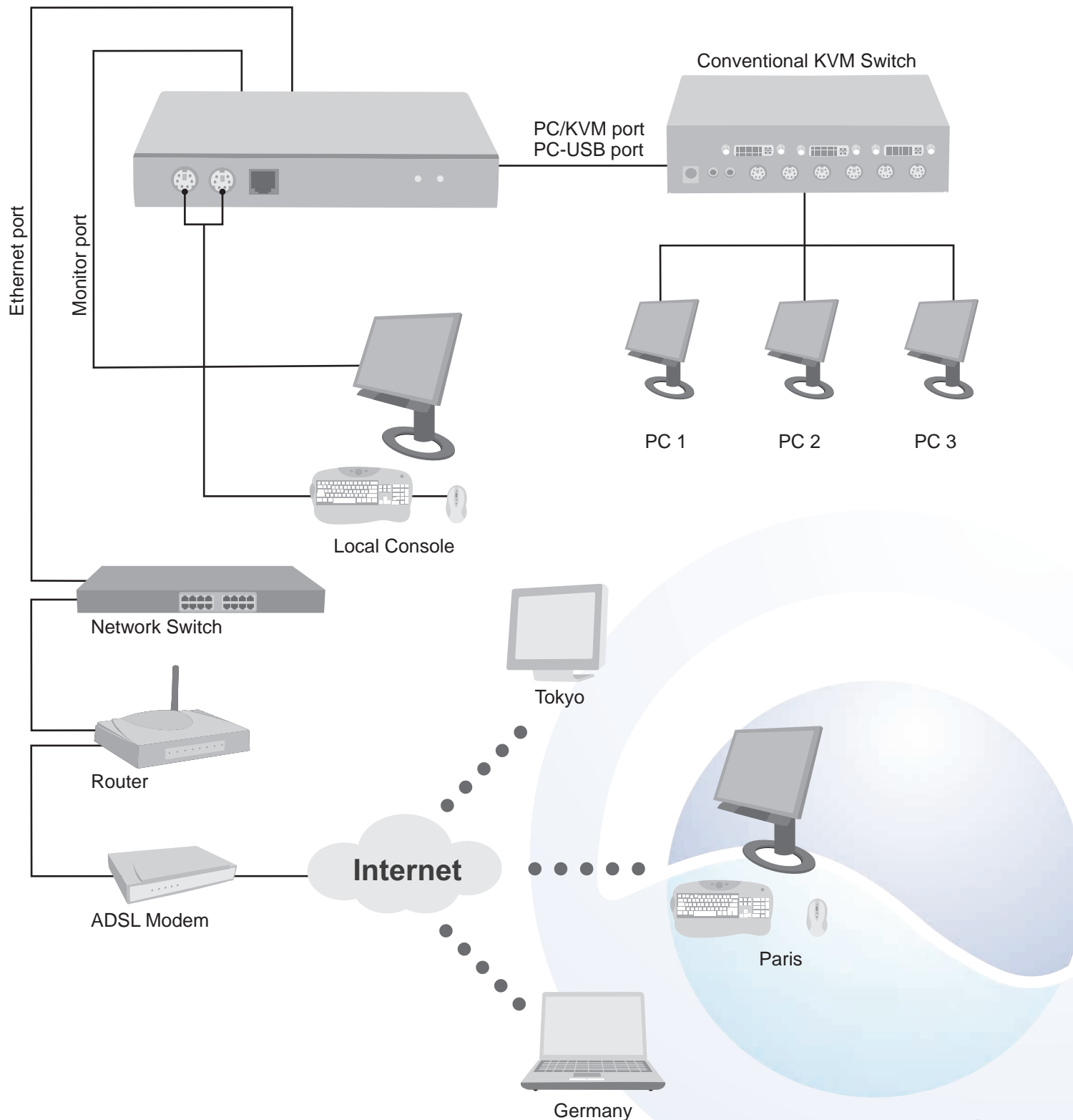

KVM Accessories

KVM Extenders are used when a PC is too far away from the keyboard, video and mouse peripherals or a KVM switch. Using standard KVM cables doesn't always suffice because of signal loss characteristics, which can cause fuzzy images and attenuated communication. KVM Extenders work in a simple yet effective manner by utilizing standard Category 5 Ethernet Cable to complete the remote connections from your PC to your KVM devices.

KVM Cables are commonly used for increasing cable lengths and often serve as replacements for old defective cables too. Standard KVM cables involve the common connections [e.g. Keyboard (PS/2), Video (VGA), Mouse (PS/2)], and are the most widely used. There are also proprietary cables that incorporate different types of connection interfaces, but these cables sometimes are limited to specific KVM switches because of their unique wiring schemes.

Extend PC 152m Away from your Remote Console and KVM Switch

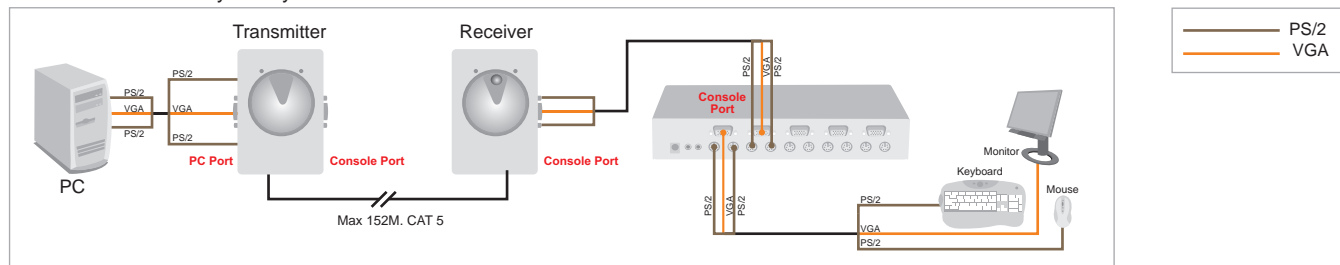

Extend KVM Switch 152m Away from Your Remote Console

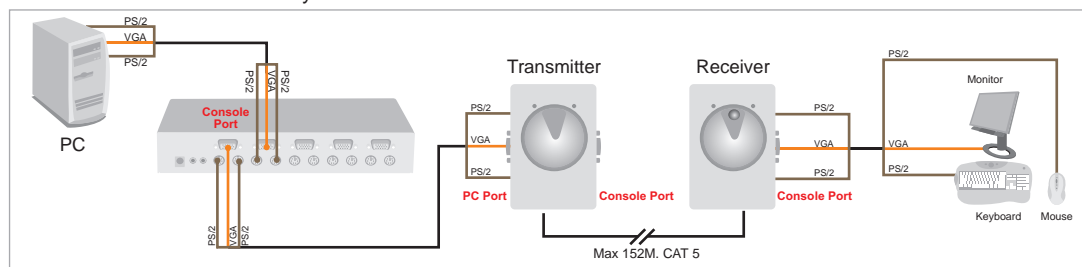



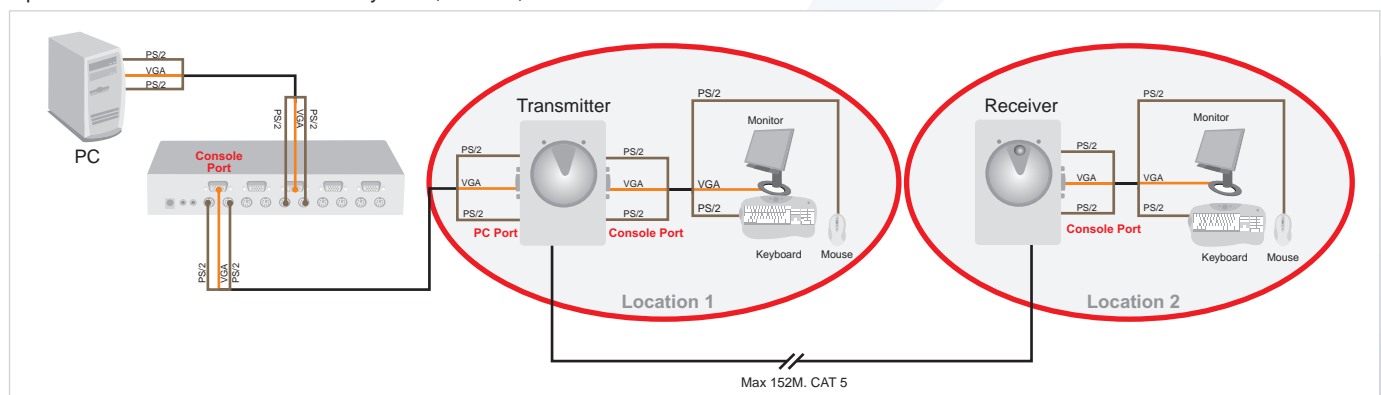



Optional: Connect a Second Set of Keyboard, Monitor, and Mouse



TRENDnet KVM Product Offering





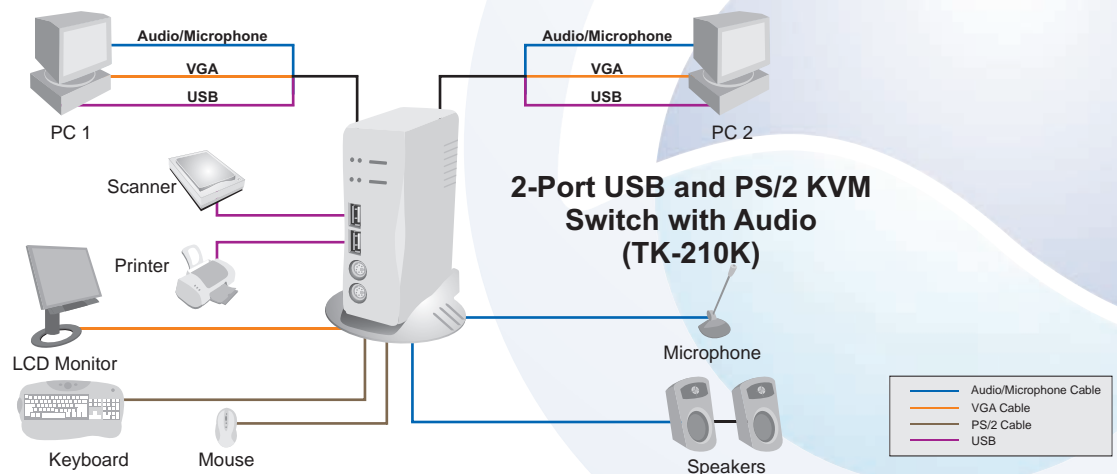

Trendnet carries a complete line of KVMs designed for multi-platform convenience. We incorporate simple yet effective features such as button and hot-key switching, making KVM operation easy. This is one of many convenient and easy to use features showcased in our KVM product line.

Up to 2 PCs

2 Computers	OS Support	PC Connection	Console Connection	Resolution	Audio Support	On Screen Display	Rackmount Ready	Cable Length	Cables Included	User Applications
 TK-200K	Windows 98/98SE/ME/2000/XP /2003 Server, Linux	PS/2 VGA	PS/2 VGA	1920x1440	X	X	X	4ft	✓	Home User Needing Basic KVM Switching Between Two Computers
 TK-204K	Windows 98/98SE/ME/2000/XP /2003 Server, Linux	PS/2 DVI Speaker Microphone	PS/2 DVI Speaker Microphone	1600x1200	Speaker Microphone	X	X	4ft	✓	Home User Needing Digital (DVI) KVM Switching Between Two Computers With Audio Support
 TK-205K	Windows 98/98SE/ME/2000/XP /2003 Server, Linux	PS/2 VGA	PS/2 VGA	2048x1536	X	X	X	4ft	✓	Home User Needing Basic KVM Switching Between Two Computers
 TK-207K	Windows 98/98SE/ME/2000/XP /2003 Server, Linux, and Mac OS	USB VGA	USB VGA	2048x1536	X	X	X	4ft	✓	Home User Needing USB KVM Switching Between Two Computers
 TK-208K	Windows 98/98SE/ME/2000/XP /2003 Server, Linux, and Mac OS	PS/2 VGA Speaker Microphone	PS/2 VGA Speaker Microphone	2048x1536	Speaker Microphone	X	X	4ft	✓	Home User Needing Basic KVM Switching Between Two Computers With Audio Support
 TK-209K	Windows 98/98SE/ME/2000/XP /2003 Server, Linux	PS/2 USB VGA Speaker Microphone	PS/2 USB VGA Speaker Microphone	1920x1440	Speaker Microphone	X	X	4ft	✓	Home User Needing Advanced KVM Switching Between Two Computers With Audio Support
 TK-210K	Windows 98/98SE/ME/2000/XP /2003 Server, Linux	PS/2 VGA Speaker Microphone 1 x USB	PS/2 VGA Speaker Microphone 2 x USB	1920x1440	Speaker Microphone	X	X	4ft	✓	Home User Needing Advanced KVM Switching Between Two Computers With Audio Support





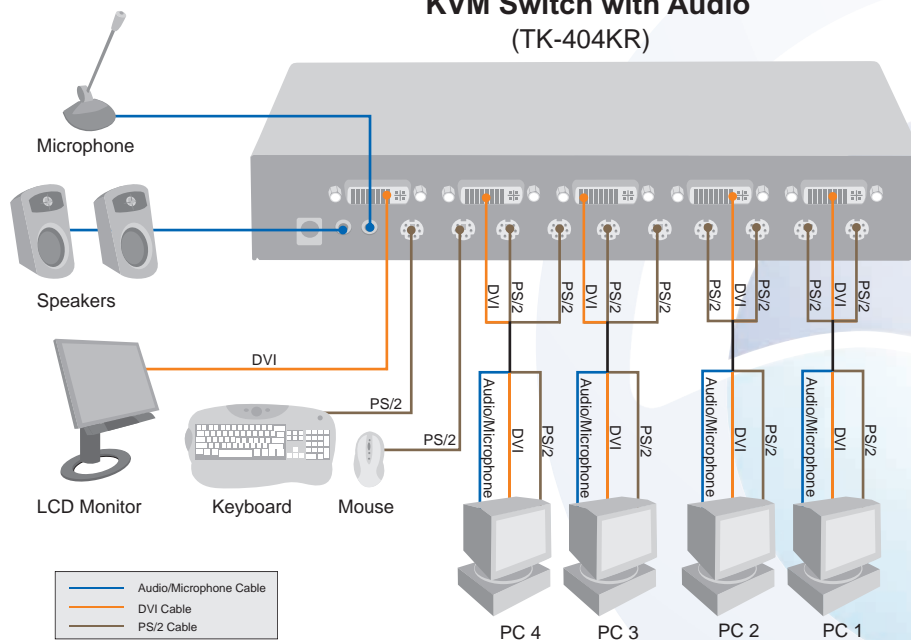

Up to 4 PCs

4 Computers	OS Support	PC Connection	Console Connection	Resolution	Audio Support	On Screen Display	Rackmount Ready	Cable Length	Cables Included	User Applications
 TK-400K	Windows 98/98SE/ME/2000/XP /2003 Server, Linux	PS/2 VGA	PS/2 VGA	1920x1440	X	X	X	6ft	✓	Home User Needing Basic KVM Switching Between Four Computers
 TK-401R	Windows 98/98SE/ME/2000/XP /2003 Server, Linux	PS/2 VGA	PS/2 VGA	1920x1440	X	X	✓	N/A	X	Office User Needing A Rackmount KVM Switching Solution Between Four Computers
 TK-403KR	Windows 98/98SE/ME/2000/XP /2003 Server, Linux	PS/2 VGA Speaker Microphone	PS/2 VGA Speaker Microphone	2048x1536	Speaker Microphone	X	✓	4ft	✓	Office User Needing A Rackmount KVM Switching Solution Between Four Computers
 TK-404KR	Windows 98/98SE/ME/2000/XP /2003 Server, Linux	PS/2 DVI Speaker Microphone	PS/2 DVI Speaker Microphone	1600x1200	Speaker Microphone	X	✓	4ft	✓	Office User Needing A Digital (DVI) Rackmount KVM Switching Solution Between Four Computers With Audio Support
 TK-407K	Windows 98/98SE/ME/2000XP/ 2003 Server, Linux	USB VGA	USB VGA	2048x1536	X	X	X	6ft	✓	Office User Needing Advanced KVM Switching Between Four Computers With Audio Support
 TK-408K	Windows 98/98SE/ME/2000XP/ 2003 Server, Linux	PS/2 VGA Speaker Microphone	PS/2 VGA Speaker Microphone	2048x1536	Speaker Microphone	X	X	6ft	✓	Office User Needing Advanced KVM Switching Between Four Computers With Audio Support
 TK-409K	Windows 98/98SE/ME/2000XP/ 2003 Server, Linux	USB VGA Speaker Microphone	USB VGA Speaker Microphone	2049x1536	Speaker Microphone	X	X	6ft	✓	Office User Needing Advanced KVM Switching Between Four Computers With Audio Support

4-Port Rack Mount DVI KVM Switch with Audio (TK-404KR)





8 to 16 PCs

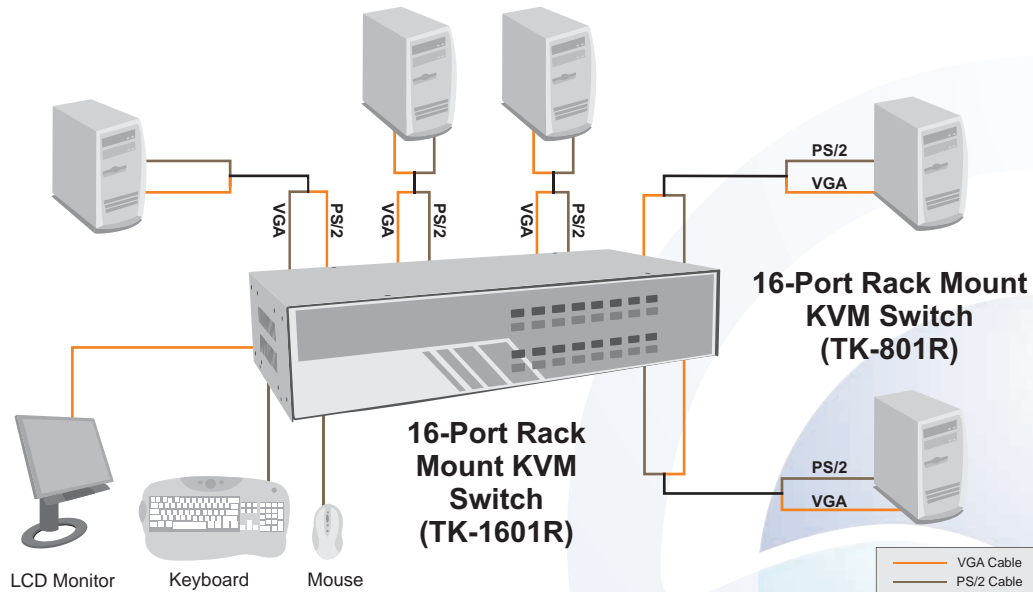

8 to 16 Pcs Computers	OS Support	PC Connection	Console Connection	Resolution	Audio Support	On Screen Display	Rackmount Ready	Number of Computers Supported	Cables Length	Cables Included	User Applications
 TK-801R	Windows 98/98SE/ME/2000/XP /2003 Server, Linux	PS/2 VGA	PS/2 VGA	1920x1440	X	X	✓	8	N/A	X	Home/Office User Needing Rackmount KVM Switching Between Eight Computers
 TK-803R	Windows 98/98SE/ME/2000/XP /2003 Server, Linux	PS/2 USB	PS/2 USB VGA	2048 X 1536	X	X	✓	8	N/A	X	Home/Office User Needing Rackmount KVM Switching Between Eight Computers
 TK-1601R	Windows 98/98SE/ME/2000/XP /2003 Server, Linux	PS/2 VGA	PS/2 VGA	1920x1440	X	X	✓	16	N/A	X	Home/Office User Needing Rackmount KVM Switching Between Sixteen Computers
 TK-1603R	Windows 98/98SE/ME/2000/XP /2003 Server, Linux	PS/2 USB VGA	PS/2 USB VGA	2048 X 1536	X	X	✓	16	N/A	X	Home/Office User Needing Rackmount KVM Switching Between Sixteen Computers



Up to 128 PCs



	OS Support	PC Connection	Console Connection	Resolution	Audio Support	On Screen Display	Rackmount Ready	Number Of KVMs Can Be Stacked	Cable Length	Maximum Range	Cables Included	User Applications
 TK-802R	Windows 98/98SE/ME/2000/XP/2003 Server, Linux	PS/2 VGA	PS/2 VGA	1920x1440	X	✓	✓	16	N/A	N/A	X	Office User Needing A Stackable KVM Switching Solution For Future Growth Demands
 TK-804R	Windows 98/98SE/ME/2000/XP/2003 Server, Linux	PS/2 USB VGA	PS/2 USB VGA	2049 X 1536	X	✓	✓	16	N/A	N/A	X	Office User Needing A Stackable KVM Switching Solution for Future Growth Demands

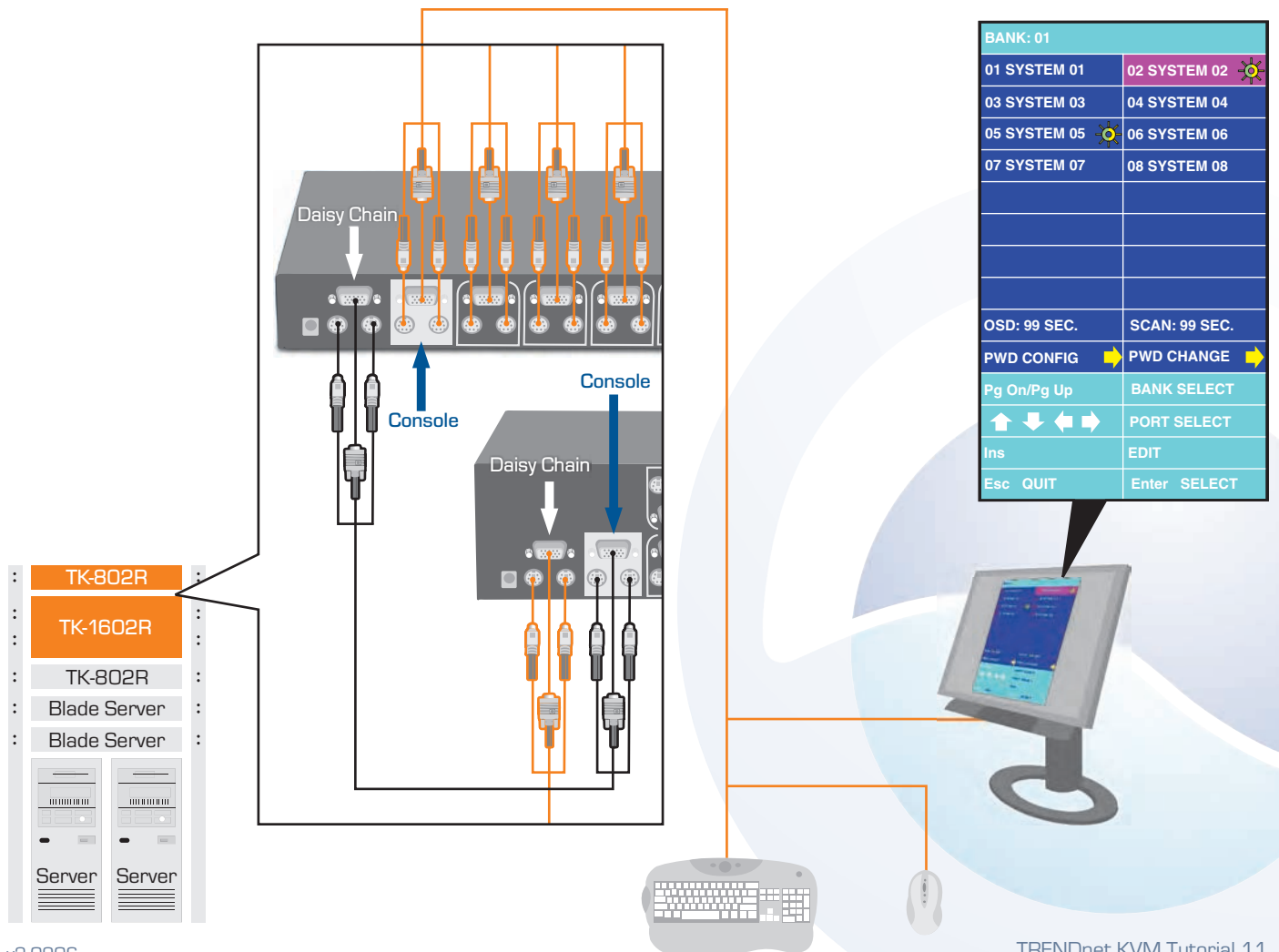

Up to 256 PCs

Up to 256 Computers	OS Support	PC Connection	Console Connection	Resolution	Audio Support	On Screen Display	Rackmount Ready	Number Of KVMs Can Be Stacked	Cable Length	Maximum Range	Cables Included	User Applications
 TK-1602R	Windows 98/98SE/ME/2000/XP/2003 Server, Linux	PS/2 VGA	PS/2 VGA	1920x1440	X	✓	✓	16	N/A	N/A	X	Office User Needing A Stackable KVM Switching Solution for Future Growth Demands
 TK-1604R	Windows 98/98SE/ME/2000/XP/2003 Server, Linux	PS/2 USB VGA	PS/2 USB VGA	2049 X 1536	X	✓	✓	16	N/A	N/A	X	Office User Needing A Stackable KVM Switching Solution for Future Growth Demands



KVM Cables

KVM Cables & Accessories		OS Support	PC Connection	Alternate PC Interfaces	Console Connection	Resolution	Audio Support	On Screen Display	Rackmount Ready	Number Of KVMs Can Be Stacked	Cable Length	Maximum Range	Cable Interface	User Applications
	TK-C06	Windows 98SE/ME/2000 /XP Linux Unix Netware	PS/2 VGA	N/A	PS/2 VGA	N/A	N/A	N/A	N/A	N/A	6ft	N/A	Male-to-Male	Home/Office User Needing Replacement Cables or Longer Cables
	TK-C10	Windows 98SE/ME/2000 /XP Linux Unix Netware	PS/2 VGA	N/A	PS/2 VGA	N/A	N/A	N/A	N/A	N/A	10ft	N/A	Male-to-Male	Home/Office User Needing Replacement Cables or Longer Cables
	TK-C15	Windows 98SE/ME/2000 /XP Linux Unix Netware	PS/2 VGA	N/A	PS/2 VGA	N/A	N/A	N/A	N/A	N/A	15ft	N/A	Male-to-Male	Home/Office User Needing Replacement Cables or Longer Cables

KVM Cables & Accessories		OS Support	PC Connection	Console Connection	Resolution	Audio Support	On Screen Display	Rackmount Ready	Number Of KVMs Can Be Stacked	Cable Length	Maximum Range	Cables Included	User Applications
	TK-CU06	Windows 98/98SE/ME/2000XP/2003 Server, Linux	USB VGA	USB VGA	N/A	N/A	N/A	N/A	N/A	6ft	N/A	Male-to-Male	Home/Office User Needing Replacement Cables or Longer Cables
	TK-CU10	Windows 98/98SE/ME/2000XP/2003 Server, Linux	USB VGA	USB VGA	N/A	N/A	N/A	N/A	N/A	10ft	N/A	Male-to-Male	Home/Office User Needing Replacement Cables or Longer Cables
	TK-CU15	Windows 98/98SE/ME/2000XP/2003 Server, Linux	USB VGA	USB VGA	N/A	N/A	N/A	N/A	N/A	15ft	N/A	Male-to-Male	Home/Office User Needing Replacement Cables or Longer Cables

KVM Extender

KVM Extender		OS Support	PC Connection	Alternate PC Interfaces	Console Connection	Resolution	Audio Support	On Screen Display	Rackmount Ready	Number Of KVMs Can Be Stacked	Cable Length	Maximum Range	Cables Included	User Applications
	TK-EX2	Windows 98SE/ME/2000 /XP Linux Unix Netware	PS/2 VGA	N/A	PS/2 VGA	1280x1024	No	No	N/A	N/A	N/A	500ft	3-in-1 KVM Cable	Home/Office User Needing To Extend The Console Devices Farther Than Conventional KVM Cables Provide

Glossary

Term	Definition
Active Port	An active port on a KVM switch is the port that is currently in use.
Auto-Scan	Auto scan allows users to view multiple computers without touching a single key. When activated, the KVM switch automatically cycles through all or selected channels, displaying each computer's video for a specified period of time.
Binding	Binding is a KVM operation that locks peripheral control to the active port of the KVM switch. In audio KVM switches, users can unbind peripheral control from the active port and listen to audio from one workstation while switching to other workstations.
Cascade	Please see "Stacking"
CAT 5	A standard RJ-45 patch cable that links devices for network communication. The KVM extender uses a CAT 5 cable to transmit keyboard, mouse, and video signals to communicate with a PC or KVM switch.
Console Port	The Console Port is where a user connects their keyboard, mouse, and video monitor.
Daisy-Chain	Please see "Stacking"
DVI	DVI stands for "Digital Video Interface". DVI monitors maximize the visual quality in flat panel, LCD monitors. KVM switches that offer DVI connectors provide crisp, digital images between switched workstations.
Hot-Key Commands	Hot-Key commands are keystroke combinations that allow a user to control the KVM switch. Using hot-keys allow a user to switch between connected workstations, scan all connected workstations automatically, unbind peripherals, and perform other KVM features.
Hot-Pluggable	The ability to add and remove devices to a computer while the workstation is powered on. KVM switches that are hot-pluggable allow users to disconnect and reconnect peripheral devices (i.e. mouse, keyboard, monitor, etc.) without turning off any workstation.
LED	LED stands for "light emitting diode". KVM switches use LEDs to visually represent an active port.
Legacy	Legacy refers to older computers that do not have recent upgrades in hardware or software.
Master Switch	A Master Switch is a KVM switch that has additional KVM switches attached. The user uses the OSD to communicate to the master switch for computer switching. Master Switches are used in stacking applications.
Microprocessor	A microprocessor is the chip set that allows switching between two workstations in a KVM switch.
OSD	OSD stands for "On Screen Display". KVM switches with OSD offer an on-screen menu that allows a user to intuitively switch from one computer to another. A user can also monitor status information from the onscreen-menu, displaying the port connection of a computer on a particular KVM switch.

Glossary

Term	Definition
PC Port	The PC Port is where a user connects a workstation to the KVM switch with a KVM cable.
Platform	Platform refers to the operating system of the user's workstation. KVM switches that offer multi-platform functionality are compatible with different operating systems such as Windows, Macintosh, or Linux.
PS/2	PS/2 is a circular connection that is primarily used for keyboard and mouse.
Rack-Mountable	The ability to mount KVM Switch into a standard 19" wide server cabinet by using mounting brackets.
Slave Switch	A Slave Switch is a KVM switch that relinquishes control to the Master Switch. The user uses the OSD to communicate to the master switch and is commonly used in stacking applications.
Stacking	Stacking describes how two or more KVM switches are connected together to gain additional computer ports.
USB	USB stands for "Universal Serial Bus". USB ports are primarily used for keyboard and mouse connections, but some KVM switches use USB ports to share USB printers,