

TE100-S44
TE100-S88
10/100 Fast Ethernet Switch

User's Guide

Rev. 01 (May, 1997)

6ETHFS8...01

Printed In Taiwan



RECYCLABLE

Wichtige Sicherheitshinweise

1. Bitte lesen Sie sich diese Hinweise sorgfältig durch.
2. Heben Sie diese Anleitung für den spätern Gebrauch auf.
3. Vor jedem Reinigen ist das Gerät vom Stromnetz zu trennen. Verwenden Sie keine Flüssig- oder Aerosolreiniger. Am besten dient ein angefeuchtetes Tuch zur Reinigung.
4. Um eine Beschädigung des Gerätes zu vermeiden sollten Sie nur Zubehörteile verwenden, die vom Hersteller zugelassen sind.
5. Das Gerät ist vor Feuchtigkeit zu schützen.
6. Bei der Aufstellung des Gerätes ist auf sichern Stand zu achten. Ein Kippen oder Fallen könnte Verletzungen hervorrufen. Verwenden Sie nur sichere Standorte und beachten Sie die Aufstellhinweise des Herstellers.
7. Die Belüftungsöffnungen dienen zur Luftzirkulation die das Gerät vor Überhitzung schützt. Sorgen Sie dafür, daß diese Öffnungen nicht abgedeckt werden.
8. Beachten Sie beim Anschluß an das Stromnetz die Anschlußwerte.
9. Die Netzanschlußsteckdose muß aus Gründen der elektrischen Sicherheit einen Schutzleiterkontakt haben.
10. Verlegen Sie die Netzanschlußleitung so, daß niemand darüber fallen kann. Es sollte auch nichts auf der Leitung abgestellt werden.
11. Alle Hinweise und Warnungen die sich am Geräten befinden sind zu beachten.
12. Wird das Gerät über einen längeren Zeitraum nicht benutzt, sollten Sie es vom Stromnetz trennen. Somit wird im Falle einer Überspannung eine Beschädigung vermieden.
13. Durch die Lüftungsöffnungen dürfen niemals Gegenstände oder Flüssigkeiten in das Gerät gelangen. Dies könnte einen Brand bzw. Elektrischen Schlag auslösen.
14. Öffnen Sie niemals das Gerät. Das Gerät darf aus Gründen der elektrischen Sicherheit nur von autorisiertem Servicepersonal geöffnet werden.
15. Wenn folgende Situationen auftreten ist das Gerät vom Stromnetz zu trennen und von einer qualifizierten Servicestelle zu überprüfen:
 - a – Netzkabel oder Netzstecker sind beschädigt.
 - b – Flüssigkeit ist in das Gerät eingedrungen.
 - c – Das Gerät war Feuchtigkeit ausgesetzt.
 - d – Wenn das Gerät nicht der Bedienungsanleitung entsprechend funktioniert oder Sie mit Hilfe dieser Anleitung keine Verbesserung erzielen.
 - e – Das Gerät ist gefallen und/oder das Gehäuse ist beschädigt.
 - f – Wenn das Gerät deutliche Anzeichen eines Defektes aufweist.
16. Bei Reparaturen dürfen nur Originalersatzteile bzw. den Originalteilen entsprechende Teile verwendet werden. Der Einsatz von ungeeigneten Ersatzteilen kann eine weitere Beschädigung hervorrufen.
17. Wenden Sie sich mit allen Fragen die Service und Repartur betreffen an Ihren Servicepartner. Somit stellen Sie die Betriebssicherheit des Gerätes sicher.

Trademarks

All rights reserved, contents subject to change without prior notice.

Ethernet is a trademark of Xerox Corporation.

Microsoft Windows is a trademark of Microsoft Corporation.

All other trademarks belong to their respective proprietors.

FCC Warning

This equipment has been tested and found to comply with the limits for a Class A digital device, pursuant to Part 15 of the FCC Rules. These limits are designed to provide reasonable protection against harmful interference when the equipment is operated in a commercial environment. This equipment generates, uses, and can radiate radio frequency energy and, if not installed and used in accordance with this user's guide, may cause harmful interference to radio communications. Operation of this equipment in a residential area is likely to cause harmful interference in which case the user will be required to correct the interference at his own expense.

TABLE OF CONTENTS

ABOUT THIS GUIDE	VII
PURPOSE	VII
TERMS/USAGE	VII
OVERVIEW OF THIS USER'S GUIDE.....	VIII
INTRODUCTION	1
FAST ETHERNET TECHNOLOGY	1
SWITCHING TECHNOLOGY	2
FEATURES	3
<i>Performance features</i>	4
UNPACKING AND SETUP	6
UNPACKING	6
SETUP	7
DESKTOP OR SHELF INSTALLATION	7
WALL INSTALLATION (TE100-S44).....	8
RACK INSTALLATION (TE100-S88)	9
POWER ON.....	11
<i>TE100-S44</i>	<i>Error! Bookmark not defined.</i>
<i>TE100-S88</i>	<i>Error! Bookmark not defined.</i>
<i>LED Indicators</i>	11
<i>Power Failure</i>	12
IDENTIFYING EXTERNAL COMPONENTS	13
FRONT PANEL	13
REAR PANEL	14
<i>TE100-S44</i>	<i>Error! Bookmark not defined.</i>
<i>TE100-S88</i>	<i>Error! Bookmark not defined.</i>
LED INDICATORS	16

CONNECTING THE SWITCH	18
PC TO SWITCH	18
HUB TO SWITCH.....	19
<i>10Base-T Hub</i>	20
<i>100Base-T Hub</i>	20
HUB WITHOUT UPLINK (MDI-II) PORT	21
<i>Using straight cable</i>	21
<i>Using crossover cable</i>	21
SWITCH TO SWITCH (OTHER DEVICES)	22
<i>Using straight cable</i>	22
<i>Using crossover cable</i>	22
TECHNICAL SPECIFICATIONS.....	25
RJ-45 PIN SPECIFICATION	28
INDEX.....	30

ABOUT THIS GUIDE

Congratulations on your purchase of the 10/100 Fast Ethernet Switch. This device integrates 100Mbps Fast Ethernet and 10Mbps Ethernet network environments in a highly flexible desktop package.

Purpose

This manual discusses how to install your TE100-S44/TE100-S88 10/100 Fast Ethernet Switch.

Terms/Usage

For simplicity, this documentation uses the terms “Switch” (first letter upper case) to refer to the TE100-S44/TE100-S88 10/100 Fast Ethernet Switch, and “switch” (first letter lower case) to refer to all Ethernet switches, including the TE100-S44/ TE100-S88.

For simplicity and brevity, this manual discusses two 10/100 Fast Ethernet Switch models. The TE100-S44 is a four port model, and the TE100-S88 is an eight port model. These models are similar in every respect except for the number of ports. Therefore, all information provided in this manual is applicable to both models, and at particular points, the differentiating elements between them will be mentioned.

Overview of this User's Guide

- ◆ Chapter 1, *Introduction*. Describes the Switch and its features.
- ◆ Chapter 2, *Unpacking and Setup*. Helps you get started with the basic installation of the Switch.
- ◆ Chapter 3, *Identifying External Components*. Describes the front panel and LED indicators of the Switch.
- ◆ Chapter 4, *Connecting the Switch*. Tells how you can connect the TE100-S44/ TE100-S88 to your Ethernet network.
- ◆ Appendix A, *Technical Specifications*. Lists the technical (general, physical, environmental, and performance) specifications of the Switch.
- ◆ Appendix B, *RJ-45 Pin Specification*. Describes the RJ-45 receptacle/connector and the straight forward and crossover cables.

1

INTRODUCTION

This section describes the features of the TE100-S44/ TE100-S88, as well as giving some background information about Ethernet/ Fast Ethernet switching technology.

Fast Ethernet Technology

The rapid growth of LANs and desktop computing applications are fueling the need for high performance networks. A number of high-speed LAN technologies have been proposed to provide greater bandwidth and improve client/server response times. Among them, Fast Ethernet, or 100Base-T, provides a non-disruptive, smooth evolution from the current 10Base-T technology. This non-disruptive and smooth evolution virtually guarantee cost effective and high performance Fast Ethernet solutions in the years to come.

100Mbps Fast Ethernet is a new standard specified by the IEEE 802.3 LAN committee. It is an extension of the 10Mbps Ethernet standard with the ability to transmit and receive data at 100Mbps, while maintaining the CSMA/CD Ethernet protocol. Since the 100Mbps Fast Ethernet is compatible with all other 10Mbps Ethernet environments. It provides a straightforward upgrade and

takes advantage of the company's existing investment in hardware, software, and personnel training.

Switching Technology

Another approach to push beyond the limits of the Ethernet technology is the development of switching technology. A switch bridges Ethernet packets at the MAC address level of the Ethernet protocol transmitting among connected Ethernet or Fast Ethernet LAN segments.

Switching is a cost-effective way to increase the total network capacity available to users on a local area network. A switch increases network capacity and decreases network loading by making it possible for a local area network to be divided into different *segments* which don't compete with each other for network transmission capacity, giving a decreased load on each.

The switch acts as a high-speed selective bridge between the individual segments. Traffic that needs to go from one segment to another is automatically forwarded by the switch, without interfering with any other segments. This allows the total network capacity to be multiplied, while still maintaining the same network cabling and adapter cards.

For Fast Ethernet networks, a switch is an effective way of eliminating problems of chaining hubs beyond the "two-repeater limit." A switch can be used to split parts of the network into different collision domains, making it possible to expand your Fast Ethernet network beyond the 205 meter network diameter limit for 100BASE-TX networks. Switches supporting both traditional 10Mbps Ethernet and 100Mbps Fast Ethernet are also ideal for bridging between existing 10Mbps networks and new 100Mbps networks.

Switching LAN technology is a marked improvement over the previous generation of network bridges, which were characterized by higher latencies. Routers have also been used to segment local area networks, but the cost and the setup and maintenance requirements make routers relatively impractical. Today's switches are an ideal solution to most local area network congestion problems.

Features

The Switches were designed for easy installation and high performance in an environment where traffic on the network and the number of users increase continuously.

The Switches with their small, compact size were specifically designed for small to large workgroups (the 4-port switch for smaller workgroups and the 8-port for larger workgroups). These Switches can be installed where space is limited; moreover, they provide immediate access to a rapidly growing network through a wide range of user-reliable functions.

The Switches are ideal for deployment with multiple high-speed servers for shared bandwidth 10 Mbps or 100 Mbps workgroups. In 200 Mbps full-duplex mode, any port can provide workstations with a congestion-free data pipe for simultaneous access to the server.

The Switches are expandable by cascading two or more switches together. As all ports support 200 Mbps full duplex, the Switches can be cascaded from any port and to any number of switches.

The Switches are a perfect choice for site planning to upgrade to Fast Ethernet in the future. Ethernet workgroups can connect to the Switches now, and change adapters and hubs anytime later

without the need to change the Switches or reconfigure the network.

The Switch combines dynamic memory allocation with store-and-forward switching to ensure that the buffer is effectively allocated for each port while controlling the data flow between the transmit and receive nodes to guarantee against all possible packet loss.

The Switch is unmanaged 10/100 Fast Ethernet Switch that offers solutions in accelerating small Ethernet workgroups' bandwidths. Other key features are:

Ports 4 or 8 UTP/STP ports (depending on the model), all with auto-negotiation and operating at 10/100 Mbps for connections to servers and hubs. All ports can be configured for full or Half-duplex operation.

- ◆ Uplink/ MDI-II (media dependent interface) port for uplink to another switch, hub or repeater. Please note that if you are using the uplink port, you will be unable to use port one as these two ports are logically connected.

Performance features

- ◆ Store and forward switching scheme capability to support rate adaptation and ensures data integrity.
- ◆ N-way Auto-negotiation for any port. This allows for auto-sensing of speed (10/100 Mbps) and auto-detecting mode (Full-duplex or Half-duplex) thereby providing you with automatic and flexible solutions in your network connections.
- ◆ Auto polarity detection for correcting incorrect polarity on the receiving twisted pair cable at each port.
- ◆ Data forwarding rate 148,800 pps per port at 100% wire speed.

- ◆ Data filtering rate at 148,800 pps per port, eliminates all error packets at 100% wire speed.
- ◆ 8K active MAC address entry table per device with self learning and table aging.
- ◆ 8 MB packet buffer per device.

2

UNPACKING AND SETUP

This chapter provides unpacking and setup information for the Switches.

Unpacking

Open the shipping carton of the Switch and carefully unpack its contents. The carton should contain the following items:

- ◆ One TE100-S44 or TE100-S88 10/100 Fast Ethernet Switch
- ◆ One AC power cord
- ◆ This User's Guide
- ◆ Four rubber self-adhesive pads
- ◆ Wall Mount Kit (TE100-S44 only) which includes: two tapping screws and two plastic anchors

If any item is missing or damaged, please contact your local reseller for replacement.

Setup

The setup of the Switch can be performed using the following steps:

- ◆ Make sure that the surface supports at least 1.2 Kg for the TE100-S44 and 2.5 KG for the TE100-S88.
- ◆ The power outlet should be within 1.82 meters (6 feet) of the device.
- ◆ Make sure that the power cord is securely plugged into the AC power connector.
- ◆ Ensure that there is proper heat dissipation from and adequate ventilation around the Switch. Do not place heavy objects on the Switch.

Desktop or Shelf Installation

When installing the Switch on a desktop or shelf, the rubber pads included with the device must be attached first. Attach these cushioning pads on the bottom at each corner of the device. Allow enough ventilation space between the device and the objects around it.

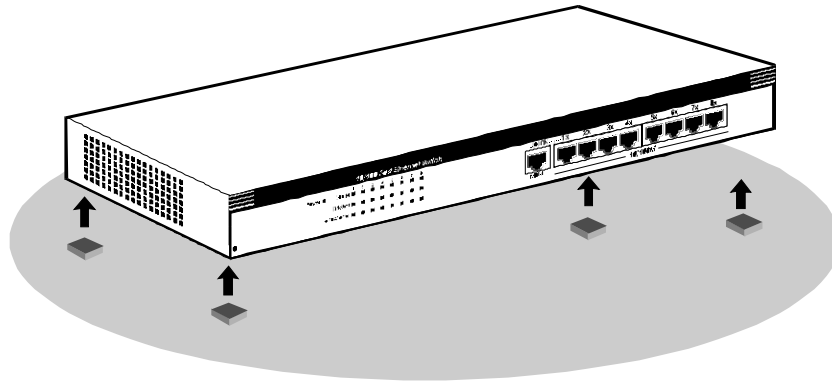

Figure 1, 10/100 Fast Ethernet Switch installed on a Desktop or Shelf

Wall Installation (TE100-S44)

The TE100-S44 comes with a wall mount kit. This kit includes two screws and two plastic anchors. For a proper placement on the wall, follow these steps:

- ◆ Select a site that is free of obstructions from other equipments or devices. Consider the following points for site selection:
 - ◇ The Switch should be placed high enough where LED indicators can be observed and cable and power connections can be made.
 - ◇ Moreover, decide whether the Switch's front panel should face either up or down.

- ◆ Drill two 2" deep holes on the wall. The distance between the holes should be the same as the screw support holes located on the bottom of the Switch.
- ◆ Insert the plastic anchors into the holes in the wall and secure them with gentle taps of a hammer.
- ◆ Screw in the screws provided with the wall mount kit into the plastic anchors. Please note that the screw's head along with a small portion (1/8") of the screw's body should be sticking out.
- ◆ Gently, place the Switch on the wall with the front panel facing up or down. Align the holes on the bottom of the Switch to the screws and mount the Switch on the wall by sliding the slots into the screws.
- ◆ Make all power and network connections at this time, see *Connecting the Switch*.

Rack Installation (TE100-S88)

The TE100-S88 can be mounted in an EIA standard size, 19-inch rack, which can be placed in a wiring closet with other equipment. **The mounting brackets for the TE100-S88 are an optional item and must be purchased separately from your local reseller.** To install, attach the mounting brackets on the switch's front panel (one on each side) and secure them with the screws provided.

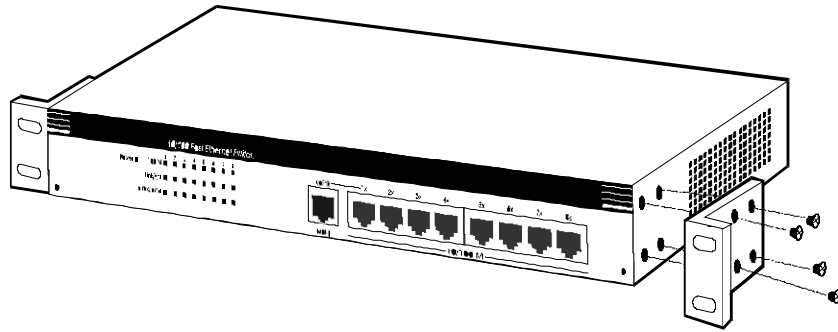

Figure 2A, Attaching the mounting brackets to the 10/100 Fast Ethernet Switch

Then, use the screws provided with the equipment rack to mount the Switch in the rack.

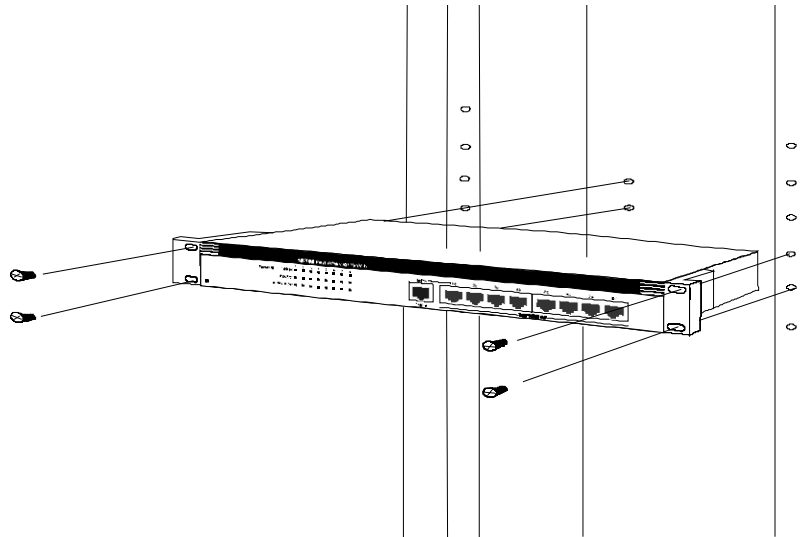

Figure 2B, Installing the 10/100 Fast Ethernet Switch on the equipment rack

Power on

TE100-S44

The TE100-S44 Switch can be used with AC power sources 100 - 240 VAC, 50 - 60 Hz. To turn the Switch on, plug one end of the power cord into the AC power connector of the Switch and the other end into the local power source outlet. The Switch's power supply will adjust to the local power source automatically and may be turned on without having any or all LAN segment cables connected.

TE100-S88

The TE100-S88 Switch can be used with AC power sources 100 - 240 VAC, 50 - 60 Hz. The power switch is located at the rear of the unit adjacent to the AC power connector and the system fan. To turn the Switch on, press the power switch to the on or "1" position. The Switch's power supply will adjust to the local power source automatically and may be turned on without having any or all LAN segment cables connected.

LED Indicators

After the switch is turned on, the LED indicators should respond as follows:

- ◆ All of the LED indicators will blink momentarily. This blinking of the LED indicators represents a reset of the system.
- ◆ The FDX/Col LED indicators blink from **yellow** to **green**.

- ◆ The power LED indicator will remain ON.

Power Failure

As a precaution, the Switch should be turned **OFF** in case of a power failure. For the TE100-S44, disconnect the power cord from the local power source, and for the TE100-S88, press the power switch to the off or "0" position. When power is resumed, turn the Switch **ON**. Do not leave the Switch ON after the power failure.

3

IDENTIFYING EXTERNAL COMPONENTS

This chapter describes the front panel, rear panel and LED indicators of the Switch.

Front Panel

The front panel of the Switch consists of 4 (10/100 Mbps MDI-X) ports— TE100-S44 or 8 (10/100 Mbps MDI-X) ports— TE100-S88, 1 Uplink (MDI-II) port and LED indicators. A description of the ports appear in the *Introduction* of this User's Guide (see *Features*, Chapter 1).

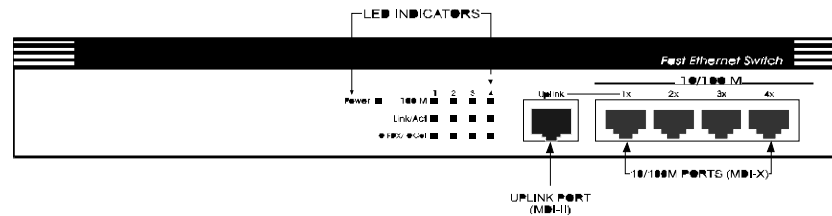

Figure 3, Front panel view of the TE100-S44 Switch

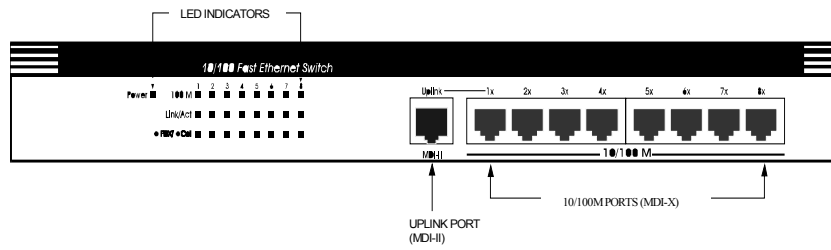

Figure 4, Front panel view of the TE100-S88 Switch

Rear Panel

TE100-S44

The rear panel of the TE100-S44 consists of an AC power connector. The system fan for the Switch is located at the sides of the device.

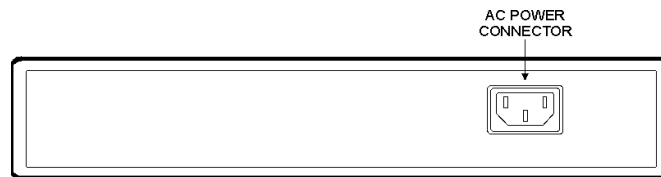

Figure 5, Rear panel view of the TE100-S44 switch

TE100-S88

The rear panel of the TE100-S88 consists of a power switch, an AC power connector and a system fan.

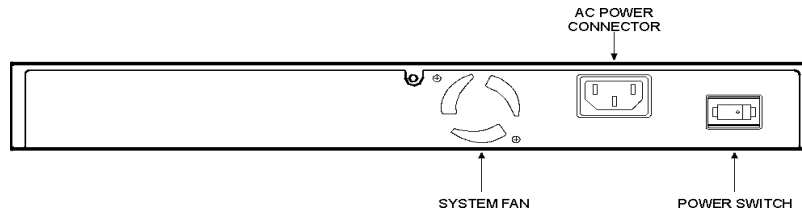

Figure 6, Rear panel view of the TE100-S88 switch

- ◆ **System Fan.** This fan is used to circulate air inside the Switch and also to dissipate heat. The sides of the system also provide heat vents to serve the same purpose. Leave adequate space at the rear and sides of the Switch for proper ventilation and do not block these openings. Please note that without proper heat dissipation and air circulation, system components might overheat, which could lead to system failure.
- ◆ **AC Power Connector.** This is a three-pronged connector that supports the power cord. Plug the female connector of the power cord into this connector, and the male connector into a power outlet. Supported input voltages range from 100 ~ 240 VAC at 50 ~ 60 Hz.
- ◆ **Power Switch. (TE100-S88 only)** This turns the Switch on and off. To turn on the system, press the switch to the “1” position. To turn the power off, press the switch to the “0” position. Please note that on the TE100-S44, the power switch is not provided.

LED Indicators

The LED indicators of the Switch include Power, 100 M, Link/Act (Link/Activity) and FDX/Col (Full-duplex/Collision). The LED indicators are used to indicate the Switch's status. The following shows the LED indicators of the Switch.

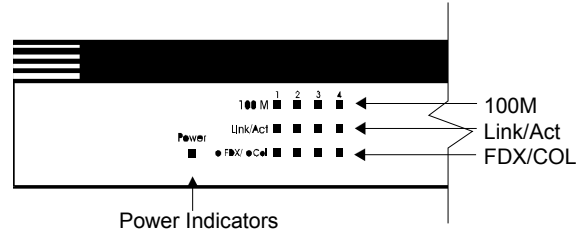

Figure 7, The TE100-S44 Switch LED indicators

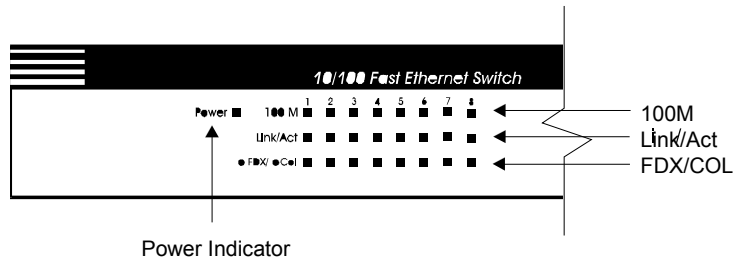

Figure 8, The TE100-S88 Switch LED indicators

- ◆ **Power.** This indicator operates when the Switch is turned on. If this indicator is not lit, make sure the AC power cable is connected properly and the power switch is at the ON position.
- ◆ **100 M.** The LED indicator lights *green* when a 100 Mbps device is connected to the port or the uplink port. If a 10

Mbps device is connected to the port or the uplink port, the LED indicator is OFF.

- ◆ **Link/Act.** These LED indicators are lighted up **green** when there is a secure connection (or link) to a device at any of the ports. The LED indicators blink **green** whenever there is reception or transmission (i.e. Activity—Act) of data occurring at a port.
- ◆ **FDX/Col.** This LED indicator is **green** when a respective port is in full duplex (FDX) mode. Otherwise, it is OFF for half duplex (HDX) operations. It blinks **yellow** when collisions are occurring on the respective port.

4

CONNECTING THE SWITCH

This chapter describes how to connect the TE100-S44/ TE100-S88 to your Fast Ethernet network. In the following figures, the TE100-S88 is shown and similar cable connections can be used on the TE100-S44.

PC to Switch

A PC can be connected to the Switch via a two-pair Category 3, 4, 5 UTP /STP straight cable. The PC (equipped with a RJ-45 10/100 Mbps jack) can be connected to any of the ports on the Switch except the up-link port.

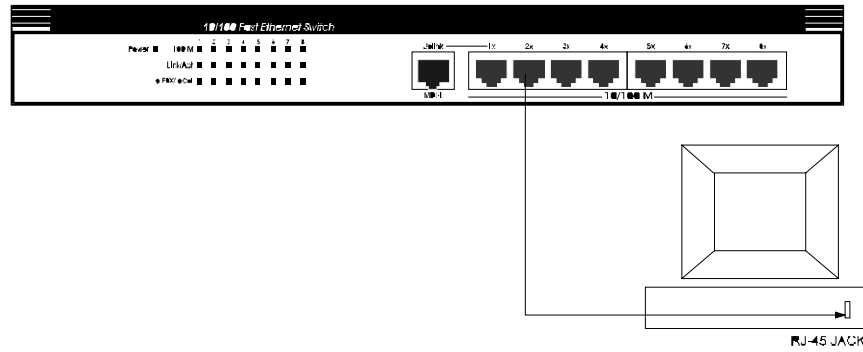

Figure 9, TE100-S88 Switch connected to a PC or Workstation

The LED indicators show the connection status between the Switch and the PCs. If LED indicators are not lit after making proper connections, check the PC's LAN card, the cable, Switch conditions and connections.

The following are the possible LED indications for a PC to Switch connection:

1. The 100 M LED indicator comes on for a 100 Mbps and stays off for 10 Mbps.
2. The Link/Act LED indicator illuminates upon hookup.
3. The FDX/Col LED indicator status depends on the LAN cards status.

Hub to Switch

A hub (10 or 100Base-T) can be connected to the Switch via a two-pair Category 3, 4, 5(required for 100Base-T) UTP/STP straight-

through cable. The connection is accomplished from the hub's uplink (MDI-II) port to any of the Switch's (MDI-X) ports: 1x - 4x for the TE100-S44 or 1x - 8x for the TE100-S88.

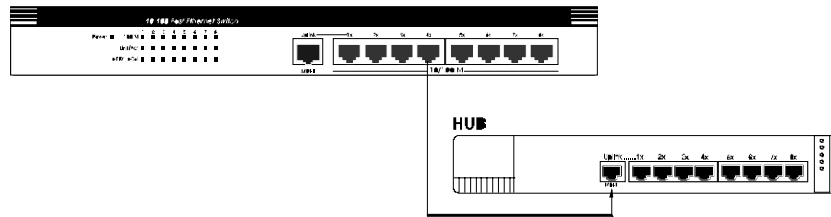

Figure 10, TE100-S88 Switch connected to a 10 or 100Base-T Hub

10Base-T Hub

If the Switch is connected to a 10 Base-T hub, the Switch's LED indicators should indicate the following:

- ◆ 100M LED speed indicator is *OFF*.
- ◆ Link/Act indicator is *ON*.
- ◆ FDX/Col indicator is *OFF*.

100Base-T Hub

If the Switch is connected to a 100Base-T hub, the Switch's LED indicators should indicate the following:

- ◆ 100M LED speed indicator is *ON*.
- ◆ Link/Act is *ON*.
- ◆ FDX/Col LED indicator is *OFF*.

Hub without Uplink (MDI-II) port

If a hub is not equipped with an uplink (MDI-II) port, then the connection can be made using either straight cable or crossover cable (see *Appendix A, Technical Specifications* for cable requirements).

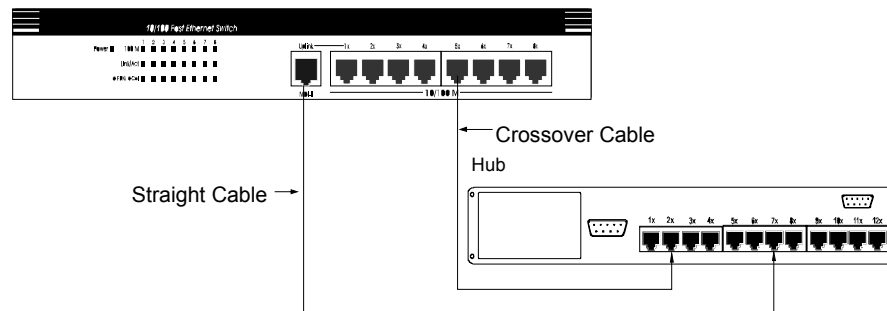

Figure 11, TE100-S88 Switch connected to a Hub without uplink (MDI-II) port using the Straight or crossover cable option

Using straight cable

When using straight cable, the connection can be made from the uplink (MDI-II) port of the Switch to any port of the Hub (see figure 11).

Using crossover cable

When using crossover cable, the connection can be made from any (1x - 8x) port of the Switch to any port of the Hub (see figure 11).

Switch to Switch (other devices)

The Switch can be connected to another switch or other devices (routers, bridges, etc.) via a two-pair Category 3, 4, 5 UTP/STP straight or crossover cable.

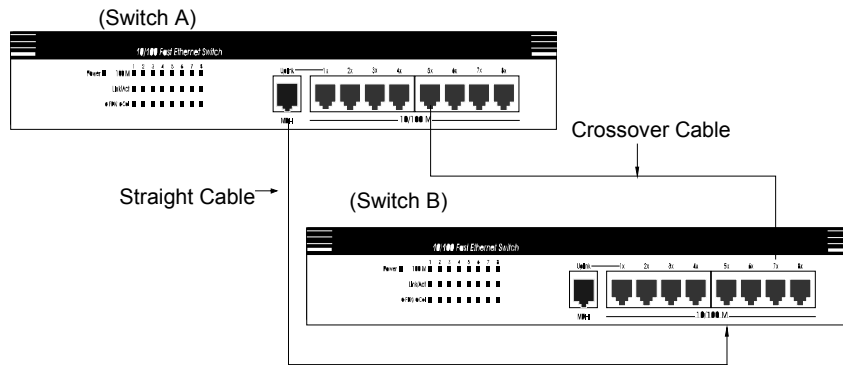

Figure 12, TE100-S88 Switch to switch connection using the straight or crossover cable options.

Using straight cable

When using straight cable, this is done from the uplink (MDI-II) port of the Switch (Switch A) to any of the 10 Mbps or 100 Mbps (MDI-X) port of the other switch (switch B) or other devices (see figure 12).

Using crossover cable

When using crossover cable, the connection can be made from any (MDI-X) port of the Switch (Switch A) to any of the 10 Mbps or 100

Mbps (MDI-X) port of the other switch (switch B) or other devices (see figure 12).

Switch A's LED status for the respective connected ports should indicate the following:

- ◆ 100 M is ON for 100Base-T, otherwise OFF.
- ◆ Link/Act is ON.
- ◆ FDX/Col status is depending on the status of the connected device.



TECHNICAL SPECIFICATIONS

General							
Standards:	IEEE 802.3 10Base-T Ethernet IEEE 802.3u 100 Base-TX Fast Ethernet ANSI/IEEE Std 802.3 N-way auto-negotiation IEEE 802.3 Frame types: Transparent IEEE 802.3 MAC layer frame size: 64 - 1518 Bytes						
Protocol:	CSMA/CD						
Data Transfer Rate:	<table style="width: 100%; border: none;"> <thead> <tr> <th style="text-align: left; border: none;">Ethernet:</th> <th style="text-align: left; border: none;">Fast Ethernet:</th> </tr> </thead> <tbody> <tr> <td style="border: none;">10 Mbps (half duplex)</td> <td style="border: none;">100Mbps (half duplex)</td> </tr> <tr> <td style="border: none;">20 Mbps (full duplex)</td> <td style="border: none;">200Mbps (full duplex)</td> </tr> </tbody> </table>	Ethernet:	Fast Ethernet:	10 Mbps (half duplex)	100Mbps (half duplex)	20 Mbps (full duplex)	200Mbps (full duplex)
Ethernet:	Fast Ethernet:						
10 Mbps (half duplex)	100Mbps (half duplex)						
20 Mbps (full duplex)	200Mbps (full duplex)						
Topology:	Star						

General	
Network Cables:	10BaseT: 2-pair UTP Cat. 3,4,5 (100 m) EIA/TIA- 568 100-ohm STP (100 m) 100Base-TX: 2-pair UTP Cat. 5 (100 m) EIA/TIA-568 100-ohm STP (100 m)
Number of Ports:	TE100-S44: 4 x 10/100 Mbps ports TE100-S88: 8 x 10/100 Mbps ports
Media Interface Exchange:	MDI-II RJ-45 shared with port 1x

Physical and Environmental	
AC inputs:	100 - 240 VAC, 50/60 Hz (internal universal power supply)
Power Consumption:	40 watts maximum
DC fans:	1 built-in 40x40 mm fan
Operating Temperature:	32 ° ~ 122 °F (0 ° ~ 50 °C)
Storage Temperature:	-22 ° ~ 140 °F (-30 ° ~ 60 °C)
Humidity:	5% ~ 95% non-condensing
Dimensions:	232x142x43 mm (1U) — TE100-S44 324x231x43 mm (1U) — TE100-S88

Physical and Environmental	
Weight:	TE100-S44: 1.2 Kg TE100-S88: 2.5 Kg
EMI:	FCC Class A, CE Mark Class A, VCCI Class I
Safety:	UL (UL 1950), CSA (CSA950), TUV/GS (EN60950)

Performance	
Transmission Method:	Store-and-forward
RAM Buffer:	TE100-S44: 4 M bytes per device TE100-S88: 8 M bytes per device
Filtering Address Table:	8 K entries per device
Packet Filtering/Forwarding Rate:	148,800 pps per port (for 100Mbps)
MAC Address Learning:	Automatic update Max age: fixed



RJ-45 PIN SPECIFICATION

When connecting the TE100-S44/ TE100-S88 Switch to another switch, a bridge or a hub, a modified crossover cable is necessary. Please review these products for matching cable pin assignment.

The following diagrams and tables show the standard RJ-45 receptacle/connector and their pin assignments for the switch-to-network adapter card connection, and the straight/ crossover cable for the Switch-to-switch/hub/bridge connection.

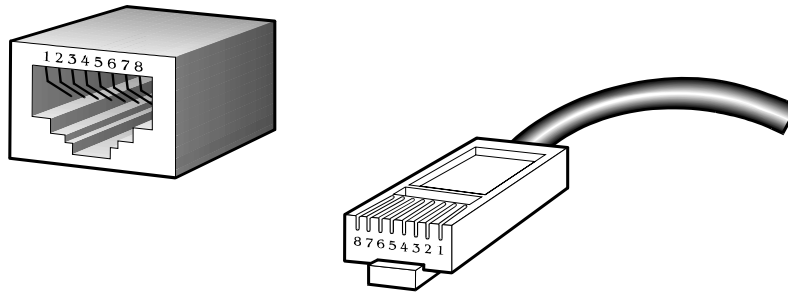

The standard RJ-45 receptacle/connector

RJ-45 Connector pin assignment	
Contact	Media Direct Interface Signal
1	Tx + (transmit)
2	Tx - (transmit)
3	Rx + (receive)
4	Not used
5	Not used
6	Rx - (receive)
7	Not used
8	Not used

The standard Category 3 cable, RJ-45 pin assignment

The following shows straight cable and crossover cable connection:

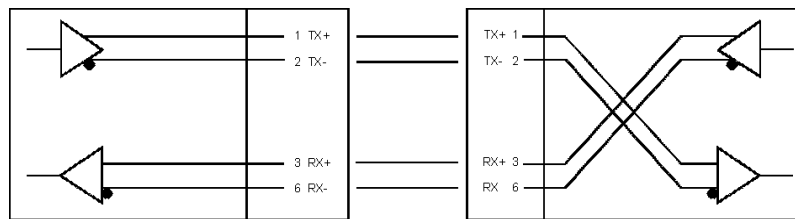

Straight cable for Switch (uplink MDI-II port) to switch/Hub or other devices connection

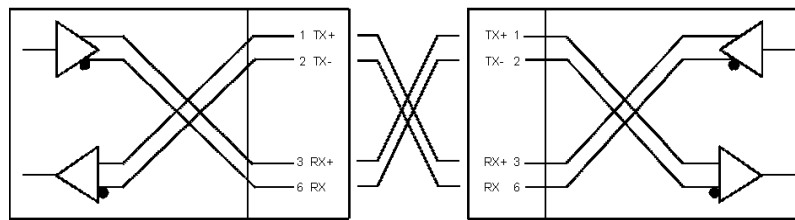

Crossover cable for Switch (MDI-X port) to switch/hub or other network devices (MDI-X port) connection

INDEX

<i>I</i>		<i>L</i>	
100 M (speed indicator)	16	LAN card	19
100Base-T	1	LED Indicators	15
<i>A</i>		Link/Act	16
AC inputs	26	<i>M</i>	
AC Power Connector	15	MAC address entry table	5
AC power cord	6	MAC Address Learning	27
Auto polarity	4	MAC address level	2
<i>C</i>		<i>N</i>	
Crossover cable	29	N-way Auto-negotiation	4
CSMA/CD Ethernet protocol	1	<i>O</i>	
<i>D</i>		Operating Temperature	26
Data filtering	5	<i>P</i>	
Data forwarding	4	PC to Switch	18
Desktop or Shelf Installation	7	Performance features	4
Dimensions	26	Ports	4
<i>F</i>		Power	16
Fast Ethernet	1	Power Consumption	26
Fast Ethernet Technology	1	Power Failure	12
FDX/Col	17	Power on	11
full duplex	17	Power Switch	15
Features	3	<i>R</i>	
Front Panel	13	Rack Installation (DES-1008)	9
<i>H</i>		RAM Buffer	27
heat dissipation	7	Rear Panel	14
Hub to Switch	19	RJ-45 Pin Specification	28
Humidity	26	<i>S</i>	
<i>I</i>		segments	2
Identifying External Components	13	Setup	7
IEEE 802.3 LAN	1	Storage Temperature	26
		Store and forward	4

straight cable	29	<i>U</i>	
switch	2		
Switch to Switch (other devices)	22	Unpacking	6
Switching LAN technology	3	Uplink/ MDI-II	4
Switching Technology	2		
System Fan	15	<i>V</i>	
<i>T</i>		ventilation	7
Transmission Method	27	<i>W</i>	
		Wall Installation (DES-1004)	8
		Weight	27

